

Cara

Universalboard

Einbauanleitung Mounting instruction Montagehandleiding Instructions de montage Istruzioni di montaggio

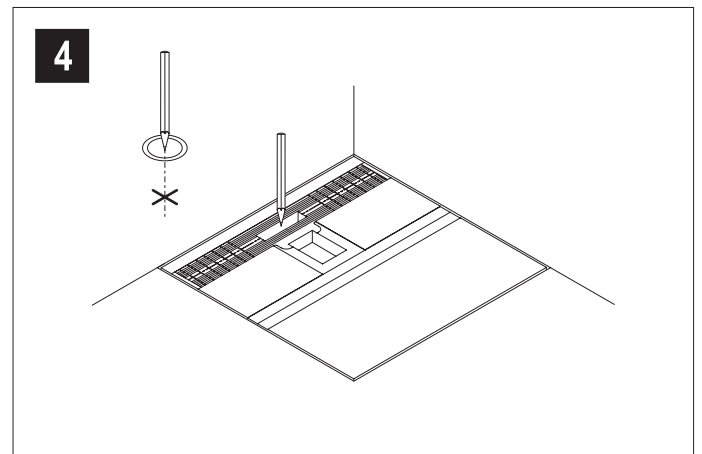
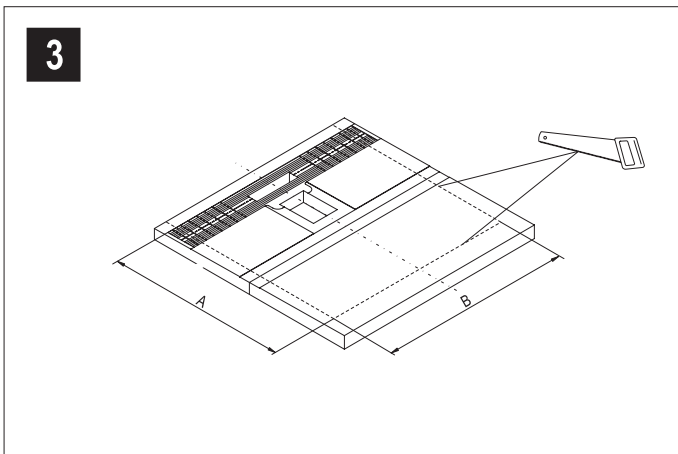
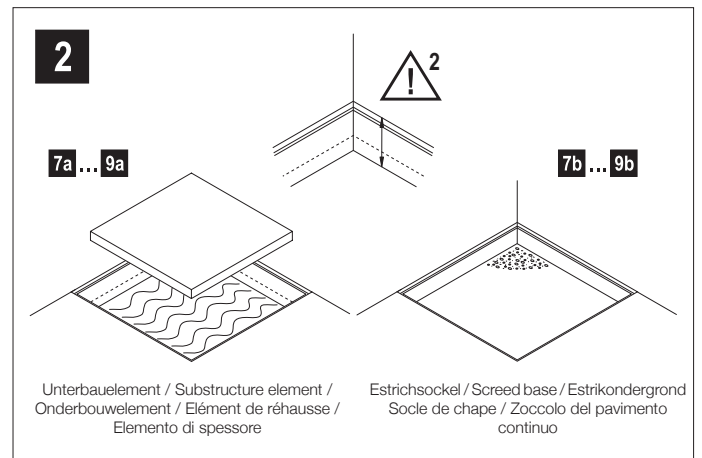
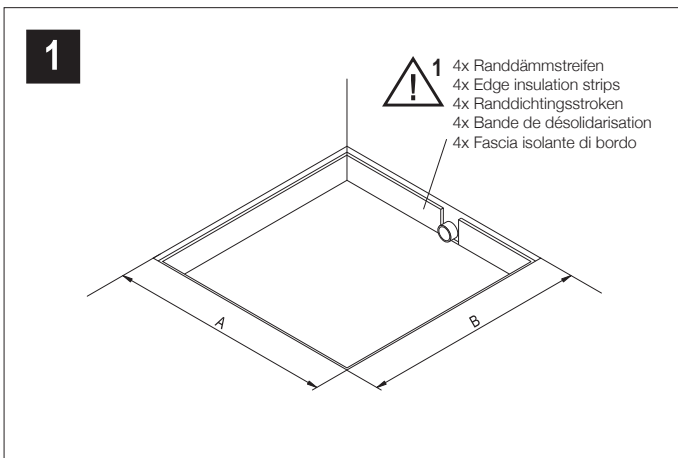
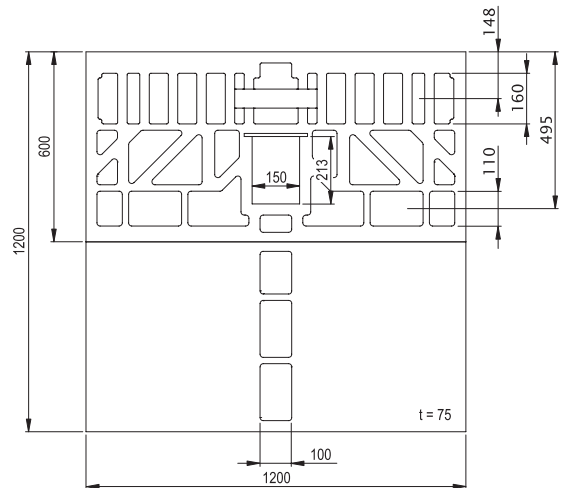
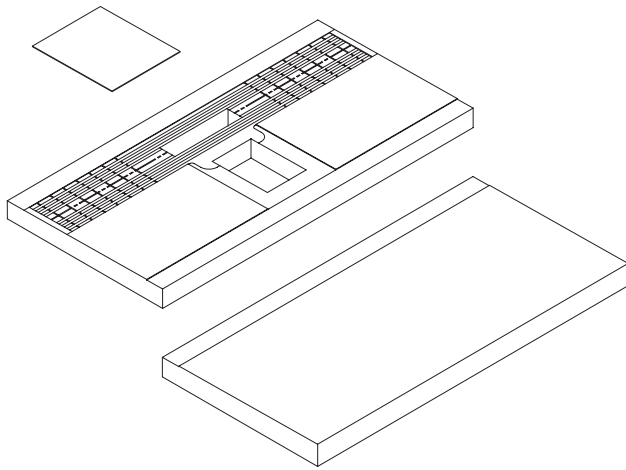

Cara

Universalboard

Einbauanleitung Mounting instruction Montagehandleiding Instructions de montage Istruzioni di montaggio

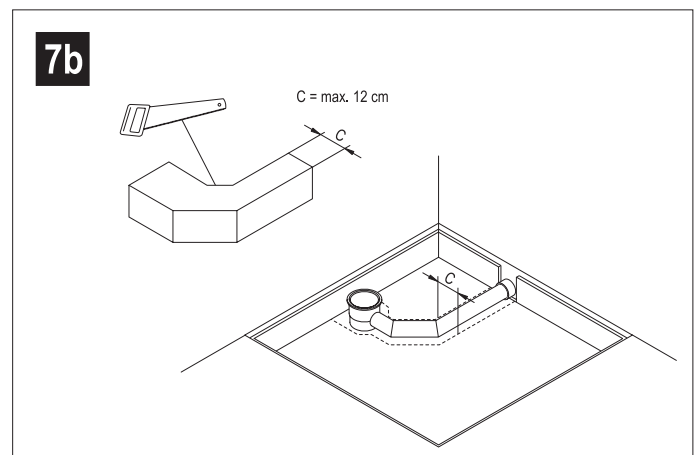
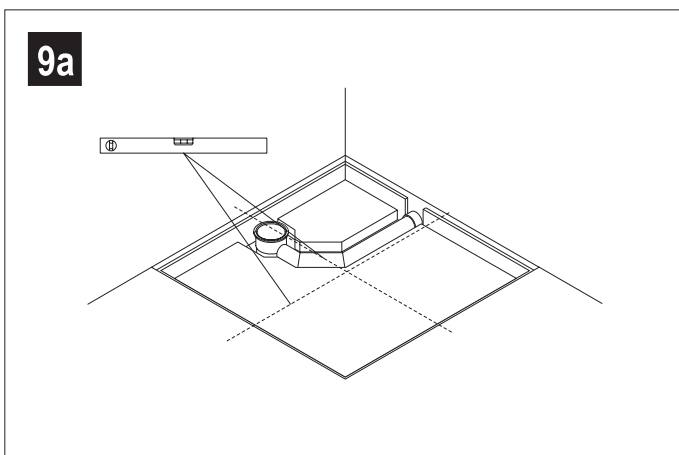
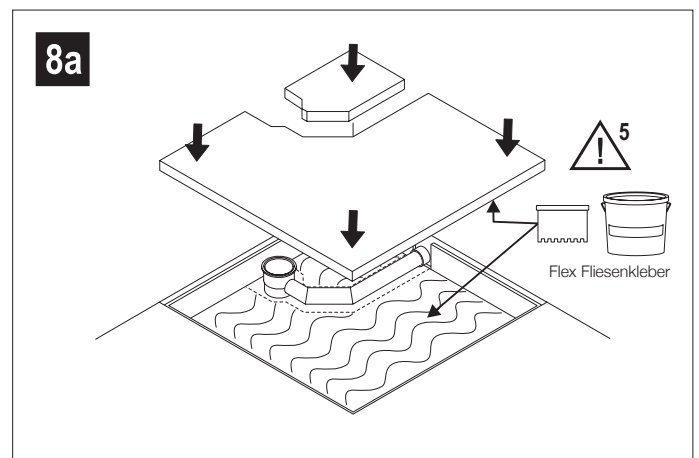
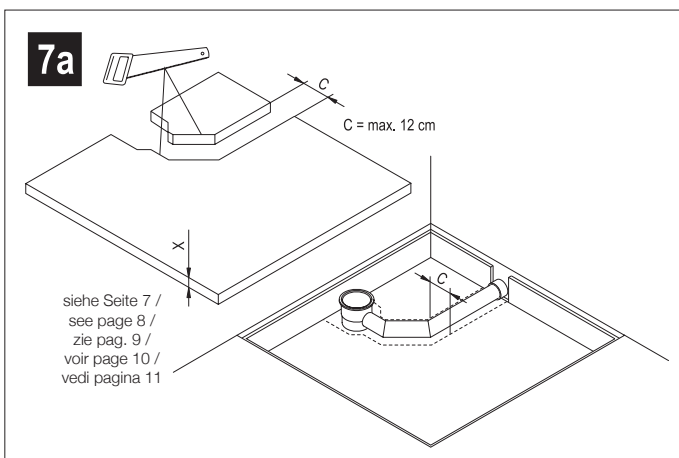
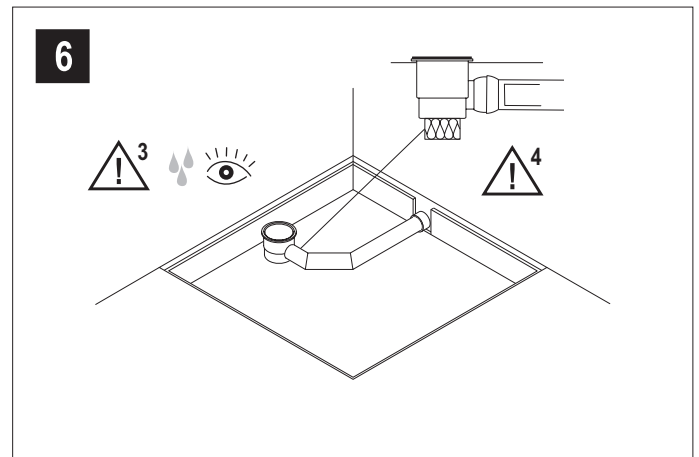
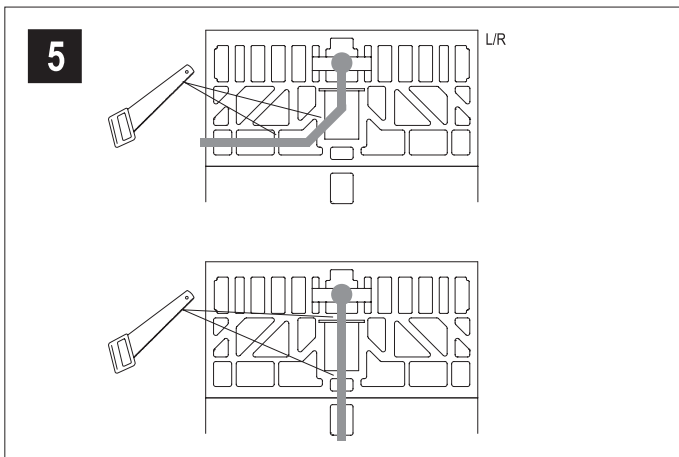

Cara

Universalboard

Einbauanleitung Mounting instruction Montagehandleiding Instructions de montage Istruzioni di montaggio

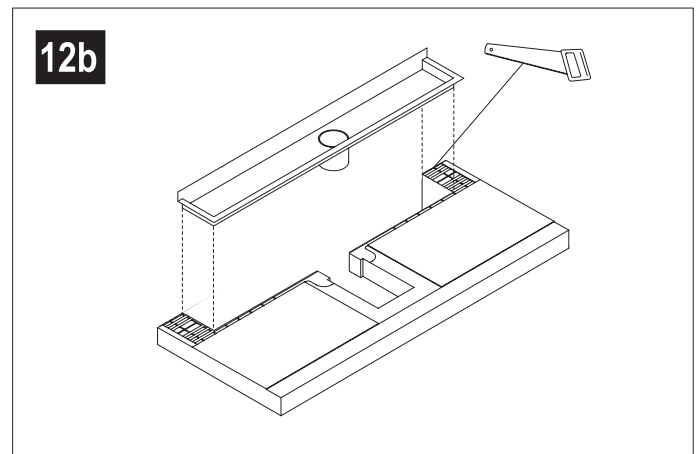
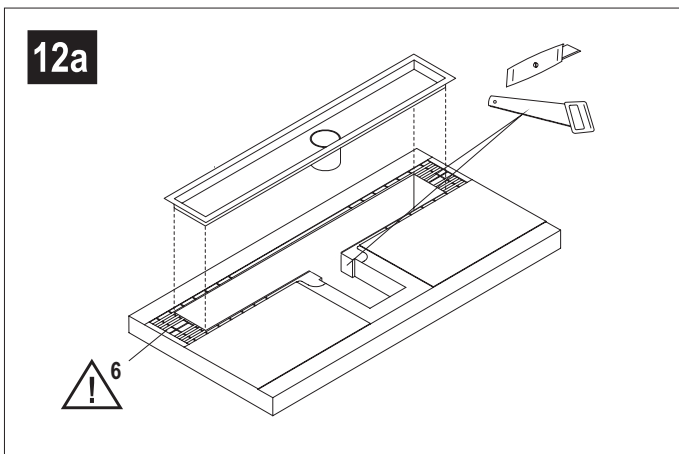
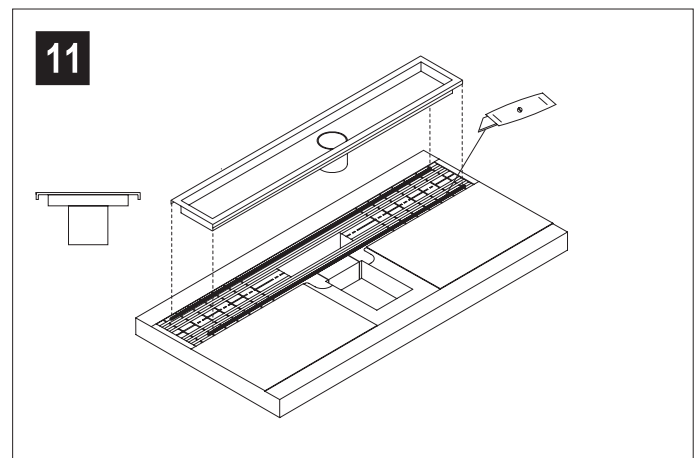
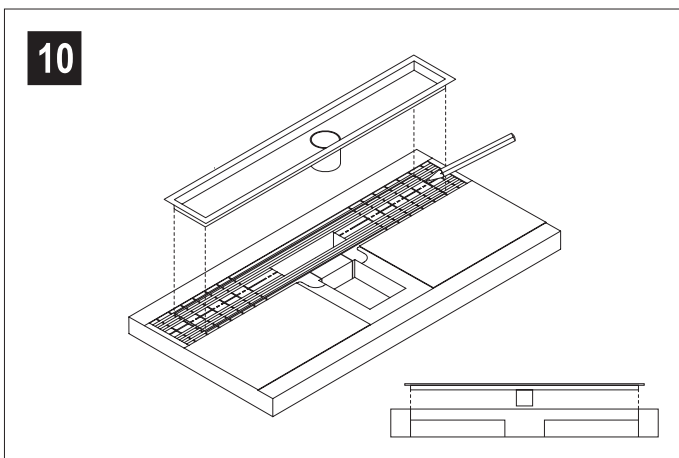
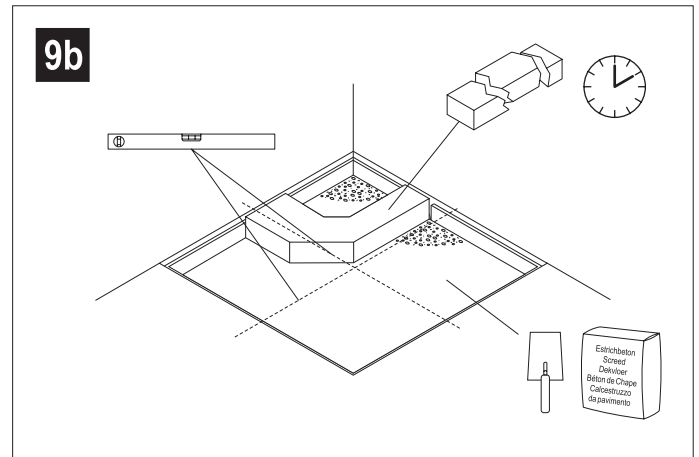
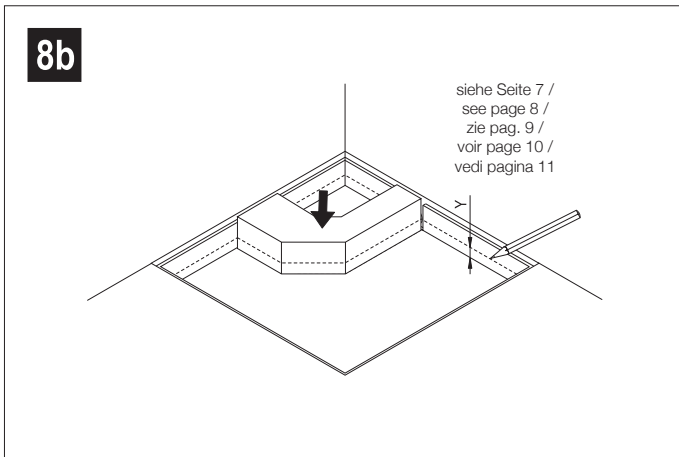

Cara

Universalboard

Einbauanleitung
Mounting instruction
Montagehandleiding
Instructions de montage
Istruzioni di montaggio

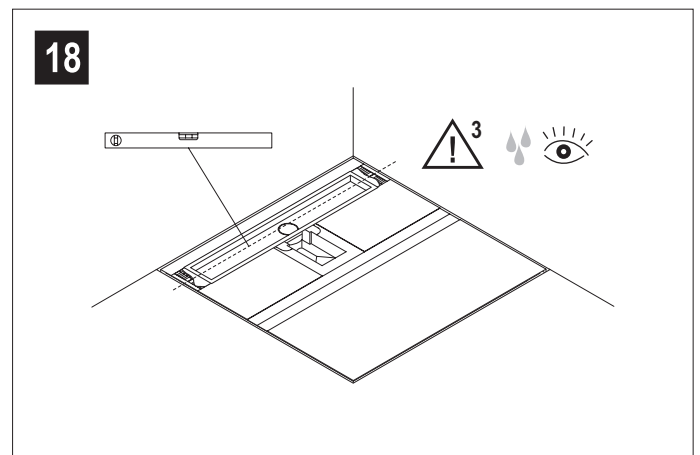
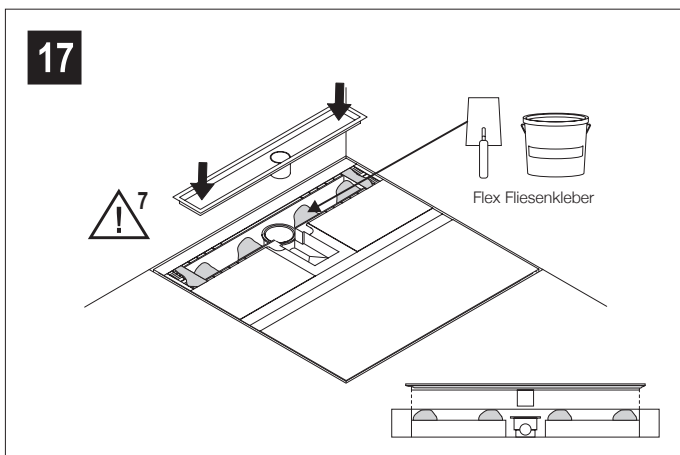
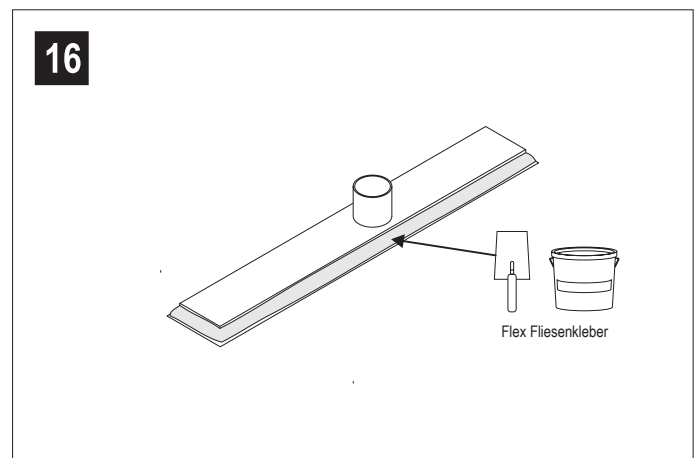
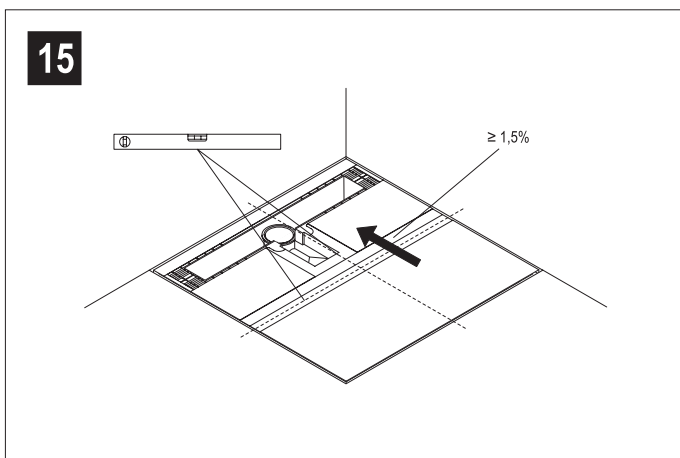
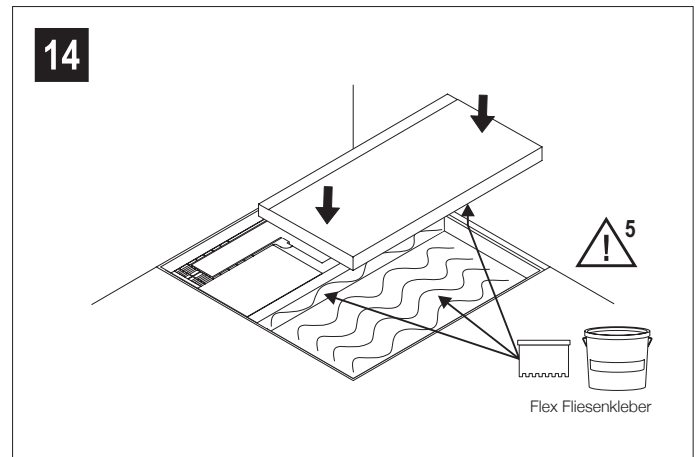
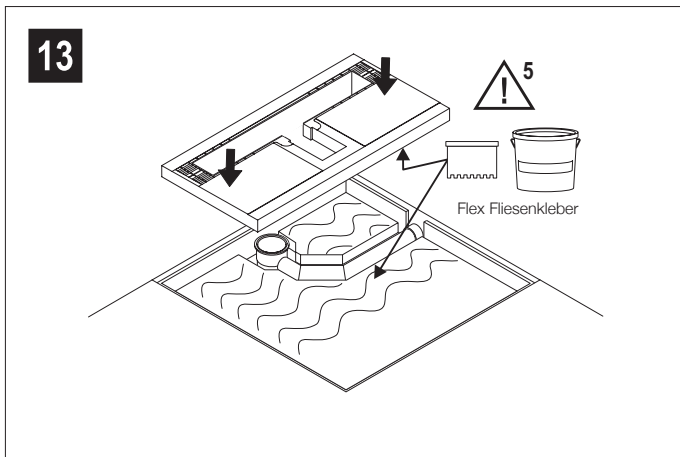

Cara

Universalboard

Einbauanleitung Mounting instruction Montagehandleiding Instructions de montage Istruzioni di montaggio

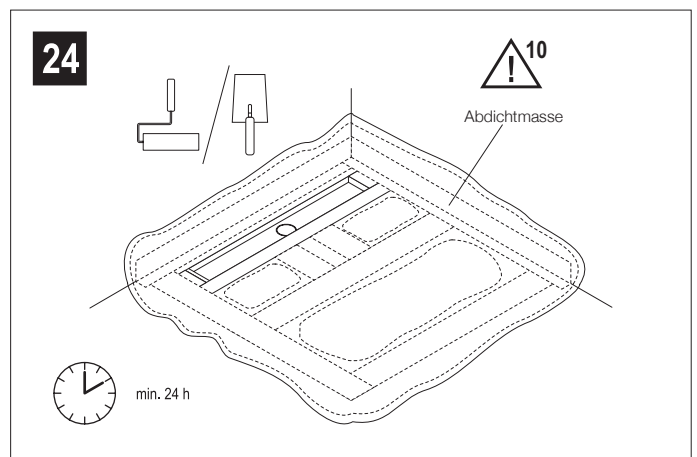
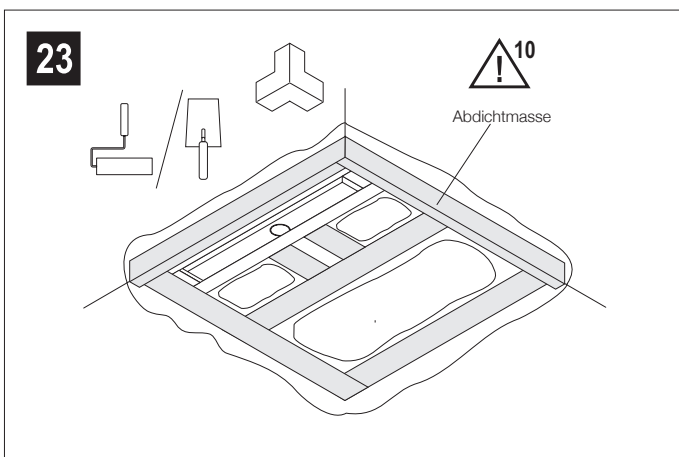
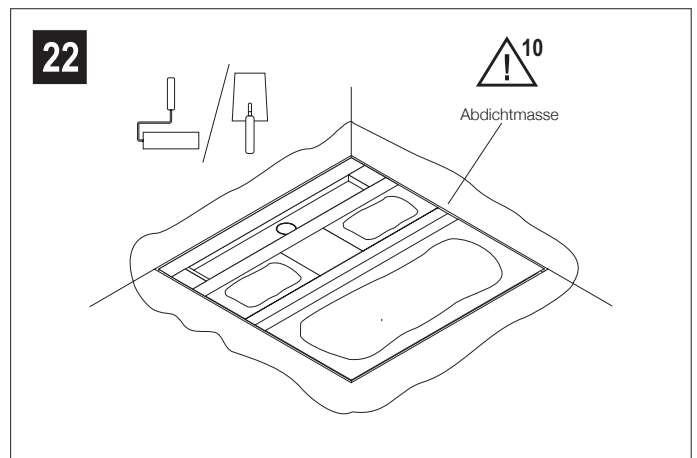
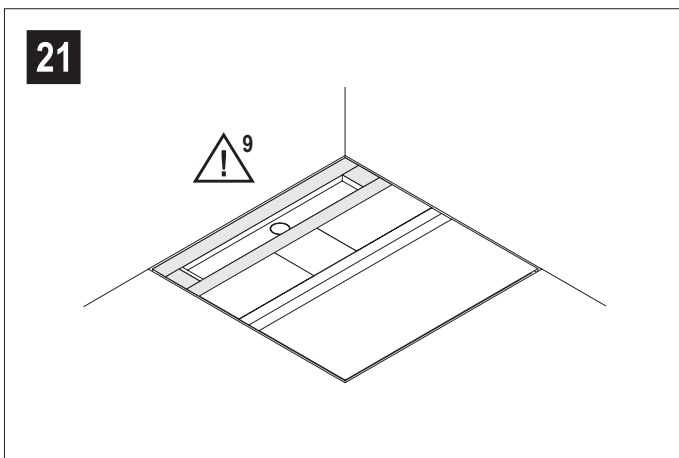
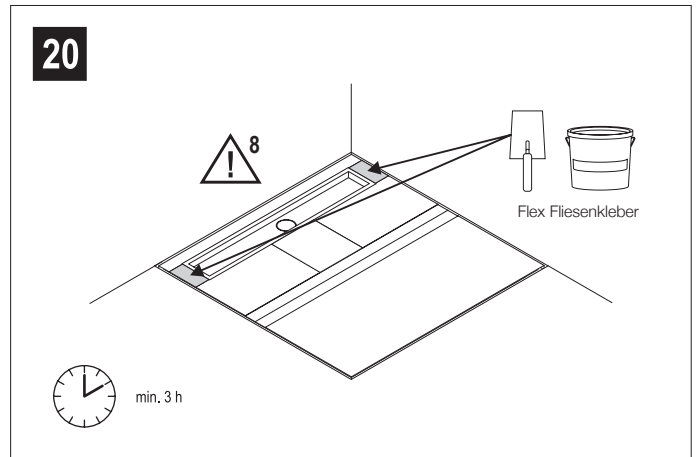
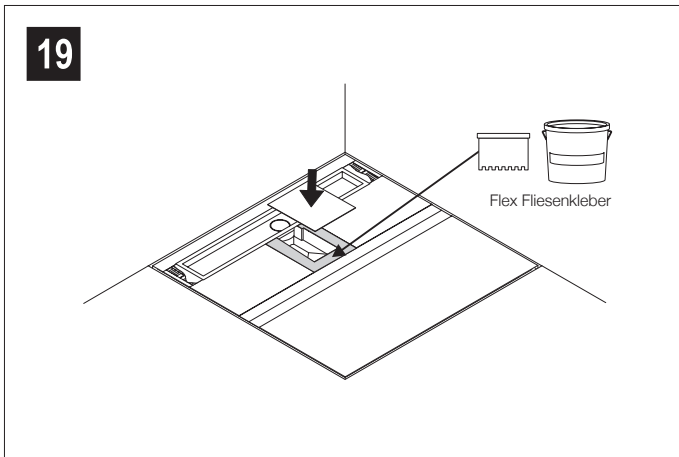

Cara

Universalboard

Einbauanleitung Mounting instruction Montagehandleiding Instructions de montage Istruzioni di montaggio

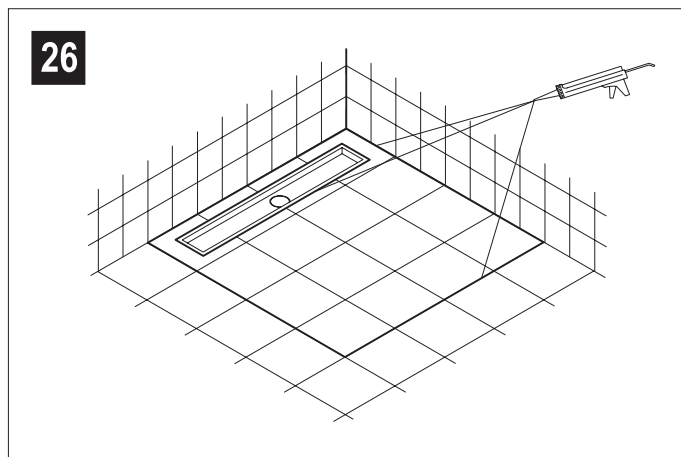
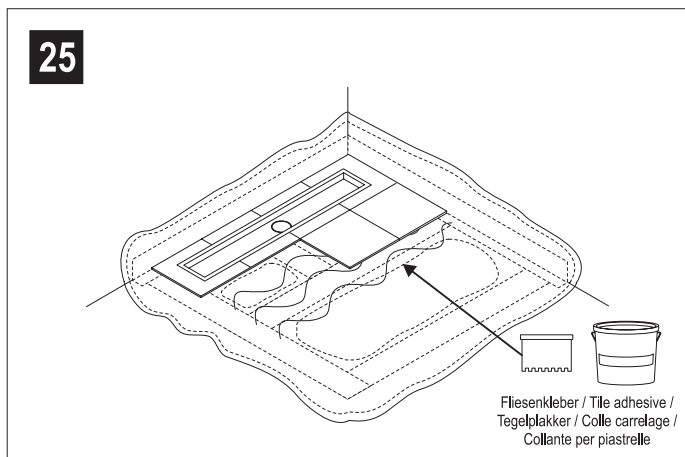

Cara

Universalboard

Einbauanleitung Mounting instruction Montagehandleiding Instructions de montage Istruzioni di montaggio

Verwendung:

- Das Cara Universalboard kann vom Verarbeiter unter Berücksichtigung der Größe, Einbauhöhe, Geometrie und des Rinnensystems umlaufend bis auf 700 mm × 700 mm gekürzt werden.
- Die Art und Weise der Nutzung des Duschplatzes (Spritzschutz, Bewegungsfläche etc.) ist zu berücksichtigen.
- Für den Einbau des Duschsystems muss ein ebener, sauberer, tragfähiger, schwingungsfreier und für die Verklebung mit Flex Fliesenkleber geeigneter Untergrund vorhanden sein.
- Das Duschsystem ist generell rollstuhlbefahrbar unter Verwendung von Fliesen mit einer Mindestgröße 100 × 100 mm. Bei Einarbeitung eines Glasgewebes in das Fliesenkleberbett können auch Fliesen mit einer Mindestgröße 50 × 50 mm verwendet werden.
- Nur für den Einsatz im Innenbereich geeignet.

 Die einschlägigen Verarbeitungsrichtlinien aller beteiligten Gewerke sind zu berücksichtigen.

 Für die Installation der Ablaufgarnitur ist die beiliegende Einbauanleitung des Herstellers zu beachten (nicht im Lieferumfang).

 1 Randdämmstreifen sind bauseits zu stellen.

 2 Beim Einbau müssen Unterbauelemente (nicht im Lieferumfang, siehe Abb. 7a bis 9a) oder ein gegossener Estrichsockel (siehe Abb. 7b bis 9b) verwendet werden. Die Höhe des Unterbauelementes/ Estrichsockels ist anhand des Höhenunterschiedes zwischen Rohfußboden und Raumestrich zu wählen (siehe auch Einbaubeispiele).

 3 Nach Installation der Ablaufgarnitur ist eine Dichtigkeitsprüfung durchzuführen.

 4 Die Ablaufgarnitur muss gegebenenfalls mit geeignetem schalldämmendem Material unterlegt werden.

 5 Flex Fliesenkleber immer beidseitig auftragen.

 6 Bei Ablaufrinnen bis zur Boardbreite muss der Rand eingeschnitten und entfernt werden.

 7 Vor Einsetzen der Ablaufrinne Hohlräume mit Flex Fliesenkleber auffüllen. Die Ablaufrinne in aufgehäuften Flex Fliesenkleber einsetzen und ausrichten.

 8 Vertiefungen im angrenzenden Rinnenbereich mit Flex Fliesenkleber aufspachteln.

 9 Das Abdichtsystem des Rinnen-Herstellers ist zu verwenden (nicht im Lieferumfang).

 10 Die Verarbeitungshinweise der Abdichtmasse sind zu beachten.

Einbaubeispiel mit Unterbauelement (X):

Aufbauhöhe/Fertigfußboden	125 mm
Cara Universalboard	- 75 mm
2 Lagen Flex Fliesenkleber	- 10 mm
<hr/>	
Unterbauelement (X)	= 40 mm

Einbaubeispiel mit Estrichsockel (Y):

Aufbauhöhe/Fertigfußboden	125 mm
Cara Universalboard	- 75 mm
1 Lage Flex Fliesenkleber	- 5 mm
<hr/>	
Estrichsockel (Y)	= 45 mm

Das Cara Universalboard erfüllt in eingebauten Zustand die Anforderungen an Baustoffe der Baustoffklasse B2 nach DIN 4102-1 (normalentflammbar) der Klasse E nach DIN EN 1350-1.

Cara

Universalboard

Einbauanleitung Mounting instruction Montagehandleiding Instructions de montage Istruzioni di montaggio

Use:

- The Cara Universalboard can be shortened by the installer up to 700 mm × 700 mm all round, considering the size, installation height, geometry and channel drain system.
- The kind of utilization of the shower space (splash protection, movement area, etc.) is to be considered.
- For installation of the shower system, a flat, clean, firm and vibration-less substrate suitable for cementing with Flex tile adhesive is required.
- The shower system is in general wheelchair-accessible, using tiles of a minimum size of 100 × 100 mm. When incorporating a fiberglass cloth in the tile adhesive bed, tiles of a minimum size of 50 × 50 mm can be used.
- Suitable for indoor use only.

 The relevant working guidelines of all the trades involved shall be observed.

 When mounting the drain fitting the enclosed installation instructions of the manufacturer must be observed (not included in the scope of supply).

 **1** Edge insulation strips are to be provided by the owner.

 **2** When installing foundation elements (not included in the scope of supply, see Figs. 7a to 9a) or a cast screed base (see Figs. 7b to 9b) can be used. The height of the foundation element/screed base is to be chosen according to the difference in level between unfinished floor and flooring screed (also see installation examples).

 **3** After the installation of the drain fitting, a leak test has to be carried out.

 **4** If necessary, the drain fitting has to be underlaid with suitable sound insulation material.

 **5** Flex tile adhesive must always be applied to both sides.

 **6** For drain boards up to board width, the edge is to be cut and removed.

 **7** Before inserting the drain board, fill the hollow spaces with Flex tile adhesive. Place the drain board in accumulated Flex tile adhesive and align it.

 **8** Depressions in the adjacent board area are to be filled with Flex tile adhesive and smoothed up.

 **9** The sealing system of the board manufacturer is to be used (not included in the scope of supply).

 **10** The processing instructions for the Sealing compound shall be observed.

Example for installation with substructure element (X):

Mounting height/finished floor level	125 mm
Cara Universalboard	- 75 mm
2 layers of Flex tile adhesive	-10 mm
<hr/>	
Substructure element (X)	= 40 mm

Installation example with screed base (Y):

Mounting height/finished floor level	125 mm
Cara Universalboard	- 75 mm
1 layer of Flex tile adhesive	- 5 mm
<hr/>	
Screed base (Y)	= 45 mm

The Cara Universalboard meets the requirements relating to the construction materials of construction material class B2 according to DIN 4102-1 (normally inflammable) of class E according to DIN EN 1350-1 in installed condition.

Cara

Universalboard

Einbauanleitung Mounting instruction Montagehandleiding Instructions de montage Istruzioni di montaggio

Toepassing:

- Het Cara Universalboard kan door de gebruiker tot 700 mm × 700 mm worden ingekort, daarbij rekening houdend met de grootte, inbouwhoogte, overige afmetingen en het rondom lopende gootsysteem.
- Er moet ook rekening worden gehouden met de gebruikswijze van de douche (spatbescherming, bewegingsruimte enz.).
- Voor montage van het douchesysteem moet een vlakke, schone en zonder vibratie dragende ondergrond aanwezig zijn, die geschikt is voor het plakken met Flex-tegelplakker.
- In het douchesysteem kan over het algemeen met een rolstoel worden gereden bij gebruikmaking van tegels met een minimale grootte van 100 × 100 mm. Bij verwerking van glasweefsel in het lijmband van de tegels kunnen ook tegels met een minimum grootte van 50 × 50 mm worden gebruikt.
- Alleen geschikt voor de toepassing binnen.

 Rekening houden met de verwerkingsrichtlijnen van alle betrokken leveranciers.

 Voor installatie van de afvoergarnituur op de bijgaande montagehandleiding van de fabrikant letten (afvoergarnituur niet in de levering inbegrepen).

 1 Randafdichtstroken moeten op de bouwplaats beschikbaar worden gesteld.

 2 Bij de montage moeten onderbouwelementen (niet bij de levering inbegrepen, zie afb. 7a tot 9a) of een gegoten estriksokkel (zie afb. 7b tot 9b) worden gebruikt. De hoogte van het onderbouwelement/estriksokkel moet aan hand van het hoogteverschil tussen ruwe vloer en ruimte-estrik worden gekozen (zie ook montagevoorbeelden).

 3 Na installatie van de afvoergarnituur op dichtheid testen.

 4 Onder de afvoergarnituur moet eventueel geschikt geluidsisolerend materiaal worden gelegd.

 5 Flex-tegelplakker altijd aan twee kanten aanbrengen.

 6 Bij afvoergoten tot boardbreedte moet de rand worden ingesneden en verwijderd.

 7 Voor het plaatsen van de afvoergoot holle ruimtes met Flex-tegelplakker opvullen. De afvoergoot in een bed van Flex-tegelplakker zetten en uitrichten.

 8 Holle ruimtes in het aangrenzende gootgedeelte met Flex-tegelplakker opvullen.

 9 Het afdichtingsysteem van de gootfabrikant moet worden gebruikt (niet bij de levering inbegrepen).

 10 De verwerkingsrichtlijnen van het Afdicht-massa moeten worden aangehouden.

Montagevoorbeeld met onderbouwelement (X):

Opbouwhoogte/afgewerkte vloer	125 mm
Cara Universalboard	- 75 mm
2 lagen Flex-tegelplakker	- 10 mm
<hr/>	
Onderbouwelement (X)	= 40 mm

Montagevoorbeeld met estrikondergrond (Y):

Opbouwhoogte/afgewerkte vloer	125 mm
Cara Universalboard	- 75 mm
1 laag Flex-tegelplakker	- 5 mm
<hr/>	
Estrikondergrond (Y)	= 45 mm

Het Cara Universalboard voldoet in ingebouwde toestand aan de eisen voor bouwmaterialen van brandklasse B2 conform DIN 4102-1 (normaal ontvlambaar) van klasse E conform DIN-EN 1350-1.

Cara

Universalboard

Einbauanleitung Mounting instruction Montagehandleiding Instructions de montage Istruzioni di montaggio

Utilisation:

- Le Cara Universalboard peut être raccourci par l'installateur tout autour jusqu'à 700 mm × 700 mm en tenant compte de la grandeur, de la hauteur hors tout, de la géométrie et du système de rigole.
- Il faut prendre en considération le mode d'utilisation du poste de douche (protection contre la projection de gouttes d'eau, espace de mouvement etc.).
- Pour le montage du système de douche, il faut avoir une surface plane, propre, stable, exempte de vibrations et appropriée à l'application de la colle carrelage Flex.
- En général, le système de douche est accessible en fauteuil roulant à la condition d'utiliser des carreaux de dimensions minimales de 100 × 100 mm. Si le lit de colle pour la pose des carreaux est renforcé par du tissu de verre, il est possible d'utiliser également des carreaux de dimensions minimales de 50 × 50 mm.
- Ne se prête qu'à l'utilisation à l'intérieur de la maison.

 Les instructions correspondantes de mise en oeuvre de tous les métiers participants sont à respecter.

 Pour l'installation de la garniture d'écoulement, respecter les instructions du fabricant qui y sont jointes (pas comprise dans la fourniture).

 1 Les bandes de désolidarisation sont à prévoir par le client.

 2 Pour l'installation, il faut mettre en place des éléments de base (non compris dans la fourniture, voir fig. 7a à 9a) ou un socle coulé de chape (voir fig. 7b à 9b). La hauteur de l'élément de base/du socle de chape est à choisir selon la différence de hauteur entre le sol brut et la chape de la salle (voir également les exemples d'installation).

 3 Après le montage de la garniture d'écoulement, procéder à une épreuve d'étanchéité.

 4 Le cas échéant, il faut placer du matériau insonorisant approprié au-dessous de la garniture d'écoulement.

 5 Appliquer la colle carrelage Flex toujours sur les deux faces.

 6 En cas de rigoles d'écoulement d'une largeur atteignant celle du « board », il faut couper le bord et l'enlever.

 7 Avant de placer la rigole d'écoulement, remplir les espaces vides de colle carrelage Flex. Placer la rigole d'écoulement dans le lit de colle carrelage Flex et l'aligner.

 8 Remplir de colle carrelage Flex les creux dans la zone adjacente à la rigole.

 9 Utiliser le système d'étanchéité (non compris dans la fourniture) du fabricant de la rigole.

 10 Respecter pour le liquide d'étanchéité le mode de mise en oeuvre indiqué par le fabricant.

Exemple d'installation avec élément de réhausse (X):

Hauteur de montage/sol fini	125 mm
Cara Universalboard	- 75 mm
2 couches de colle carrelage Flex	- 10 mm
Élément de réhausse (X)	= 40 mm

Exemple d'installation avec socle de chape (Y):

Hauteur de montage/sol fini	125 mm
Cara Universalboard	- 75 mm
1 couche de colle carrelage Flex	- 5 mm
Socle de chape (Y)	= 45 mm

Le Cara Universalboard répond, à l'état monté, aux exigences sur les matériaux du bâtiment de la catégorie de matériaux B2 conformément à DIN 4102-1 (inflammable normalement) de la catégorie E conformément à DIN EN 1350-1.

Cara

Universalboard

Einbauanleitung Mounting instruction Montagehandleiding Instructions de montage Istruzioni di montaggio

Uso:

- Il Cara Universalboard può essere accorciato dall'installatore tutt'intorno fino a 700 mm × 700 mm tenendo conto delle dimensioni, dell'altezza di montaggio, della geometria e del sistema di condotto di scolo.
- Si deve prendere in considerazione il modo d'utilizzazione del posto di doccia (protezione contro gli spruzzi di acqua, spazio di movimento ecc.).
- Per il montaggio del sistema di doccia è necessario di avere una superficie piana, pulita, stabile, esente da vibrazioni ed appropriata all'incollatura con collante per piastrelle Flex.
- Il sistema di doccia è generalmente accessibile con sedia a rotelle a condizione d'utilizzare piastrelle a dimensioni minimali 100 × 100 mm. Se il letto di colla delle piastrelle è rinforzato da tessuto di vetro, è possibile di utilizzare anche piastrelle a dimensioni minimali 50 × 50 mm.
- Solo utilizzabile all'interno della casa.

 Si deve osservare le istruzioni corrispondenti di lavorazione di tutti i mestieri partecipanti.

 Per l'installazione dell'elemento di scarico si deve osservare le istruzioni di montaggio allegate del produttore (gruppo di scarico non compreso nella fornitura).

 Fasce isolanti di bordo sono da prevedere dal cliente.

 Per il montaggio sono necessari elementi di base (non compresi nella fornitura, vedi fig. 7a a 9a) o uno zoccolo colato di pavimento (vedi fig. 7b a 9b). L'altezza dell'elemento di base/zoccolo di pavimento è da scegliere secondo la differenza di altezza fra fondo grezzo e pavimento della camera (vedi anche esempi di installazione).

 Dopo l'installazione del gruppo di scolo, si deve procedere ad una prova di tenuta.

 Eventualmente è necessario di posare materiale insonorizzante appropriato sotto il gruppo di scolo.

 Applicare collante per piastrelle Flex sempre sulle

due facce.

 **6** In caso di condotti di scolo con una larghezza fino a quella del „board“, si deve tagliare e rimuovere il bordo.

 **7** Prima della posa del canale di scolo, si deve riempire le cavità di collante per piastrelle Flex. Posare il canale di scolo nel letto di collante per piastrelle Flex ed allinearlo.

 **8** Riempire di collante per piastrelle Flex le cavità nella zona adiacente al condotto di scolo.

 **9** Utilizzare il sistema di guarnizione (non compreso nella fornitura) del produttore del condotto.

 **10** Le istruzioni di lavorazione indicate dal fabbricante per il massa di guarnizione sono da osservare.

Esempio d'installazione con elemento di spessore (X):

Altezza di montaggio/ pavimento finito	125 mm
Cara Universalboard	- 75 mm
N. 2 strati di collante per piastrelle Flex	- 10 mm
Elemento di spessore (X)	= 40 mm

Esempio d'installazione con zoccolo di pavimento (Y):

Altezza di montaggio/ pavimento finito	125 mm
Cara Universalboard	- 75 mm
N. 1 strato di collante per piastrelle Flex	- 5 mm
Zoccolo di pavimento (Y)	= 75 mm

Il Cara Universalboard adempie alle esigenze per materiali di costruzione della classe di materiali di costruzione B2 secondo DIN 4102-1 (normalmente infiammabile) della classe E secondo DIN EN 1350-1 in stato installato.

Cara

Universalboard

Einbauanleitung Mounting instruction Montagehandleiding Instructions de montage Istruzioni di montaggio

Empfohlenes Zubehör / Recommended accessories / Aanbevolen toebehoren / Accessoires recommandés / Accessori raccomandati:



Flex-Fliesenkleber / Flex tile adhesive / Flex-tegelplakker / Colle carrelage Flex / Collante per piastrelle Flex



Geeignete Abdichtmasse / Suitable Sealing compound / Geschikte Afdicht-massa / Liquide d'étanchéité approprié / Massa di guarnizione adatto

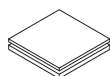

Unterbauelement / Substrate element / Onderbouwelement / Élément de réhausse / Sottostruttura



Dichtband / Sealing tape / Afdichtingsband / Bande isolante / Fascia isolante



Dichtband-Innenecke / Sealing tape interior corner / Afdichtingsband-binnenliggende hoek / Bande d'étanchéité pour coin intérieur / Fascia isolante per angolo interno

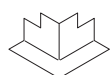

Dichtband-Außenecke / Sealing tape exterior corner / Afdichtingsband-buitenliggende hoek / Bande d'étanchéité pour coin extérieur / Fascia isolante per angolo esterno



Geeigneter Fliesenkleber / tile adhesive / Geschikte tegelplakker / Colle carrelage / Collante per piastrelle adatto



Silikon / Silicone / Siliconen / Silicone / Silicone