

AGS10 MS100-2; MS200-2, AGS10 TDS100-2 AGS10-2, AGS10E-2, AGS20-2, AGS50-2 WMZ5/10/15-2

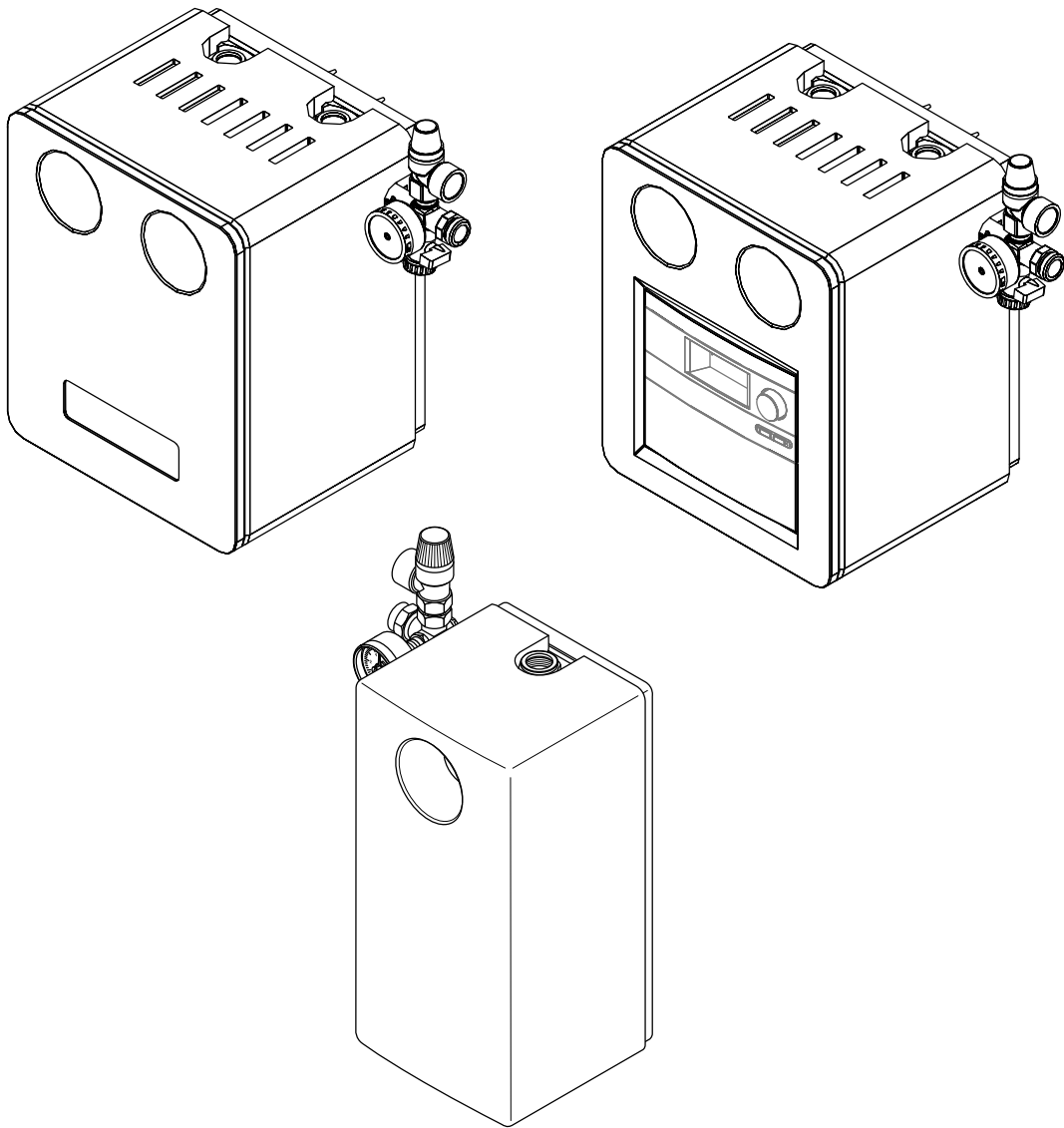

8738893134.aa.RO

[de] Wichtige Hinweise zur Installation/Montage

Die Installation/Montage muss durch eine für die Arbeiten zugelassene Fachkraft unter Beachtung der geltenden Vorschriften erfolgen.

[en] Important notes on installation/assembly

The installation/assembly must be carried out by a qualified contractor, following these instructions and in compliance with the applicable regulations.

[fr] Instructions importantes pour l'installation/le montage

L'installation/le montage doit être effectué(e) par un spécialiste qualifié pour les opérations concernées et dans le respect de la présente notice et des prescriptions applicables.

[bg] Важни указания във връзка с инсталацията/монтажа

Инсталацията/монтажът трябва да се извършва от лицензиран за работите специалист в съответствие с настоящото ръководство и с приложимите разпоредби.

[cs] Důležité pokyny k instalaci/montáži

Instalaci/montáž musí při dodržení pokynů uvedených v tomto návodu a platných předpisů provést odborný pracovník s příslušným oprávněním pro tyto práce.

[da] Vigtige anvisninger til installationen/monteringen

Installationen/monteringen skal foretages af en godkendt installatør under overholdelse af denne vejledning og de gældende forskrifter.

[el] Σημαντικές υποδείξεις για την εγκατάσταση/συναρμολόγηση

Η εγκατάσταση/τοποθέτηση πρέπει να ανατίθεται σε εκπαιδευμένο για τις συγκεκριμένες εργασίες τεχνικό προσωπικό με τήρηση αυτών των οδηγιών καθώς και των σχετικών προδιαγραφών.

[es] Indicaciones importantes para instalación/montaje

La instalación/el montaje debe realizarla personal especializado que esté autorizado para realizar estos trabajos y que tenga en cuenta estas instrucciones y la normativa vigente.

[et] Olulised juhised paigaldamiseks/montaažiks

Paigaldamist/montaaži tohib läbi viia vaid selleks volitusi omav spetsialist, arvestades kehtivaid nõudeid.

[nl-BE] Belangrijke aanwijzingen betreffende de installatie/montage

De installatie/montage moet worden uitgevoerd door een voor de werkzaamheden geautoriseerde installateur rekening houdend met deze handleiding en de geldende voorschriften.

[fi] Tärkeitä asennus- ja kokoonpano-ohjeita

Näihin töihin hyväksytyin ammattiasentajan pitää suorittaa asennus- ja kokoonpanotyöt voimassa olevien määräysten mukaisesti.

[hu] Fontos tudnivalók az installáláshoz/szereléshez

A telepítést/szerelést egy, a munkálatokra felhatalmazott szakembernek kell végeznie, jelen utasítás és az érvényes előírások figyelembevételével.

[it] Avvertenze importanti per l'installazione/il montaggio

L'installazione/il montaggio deve aver luogo ad opera di una ditta specializzata ed autorizzata in osservanza di queste istruzioni e delle direttive vigenti.

[ka] მნიშვნელოვანი მითითებები ინსტალაციისთვის/მონტაჟისთვის

ინსტალაცია/მონტაჟი უნდა განხორციელდეს საშუალებისთვის დამკვეთი კვალიფიციური პერსონალის მიერ, მოქმედი განაწესის დაცვით.

[lt] Svarbios instaliavimo ir (arba) montavimo nuorodos

Instaliavimo / montavimo darbus, laikydamiės šios instrukcijos reikalavimų ir galiojančių taisyklių, privalo atlikti šioms darbams įgalioti specialistai.

[lv] Svarīgi norādījumi par iekārtas uzstādīšanu / montāžu

Uzstādīšanu/montāžu jāveic atbilstošajiem darbiem sertificētam speciālistam, ievērojot šo instrukciju un spēkā esošos noteikumus.

[nl] Belangrijke aanwijzingen betreffende de installatie/montage

De installatie/montage moet door een erkend installateur volgens de geldende voorschriften worden uitgevoerd.

[no] Viktig informasjon om installasjon/montering

Installasjonen/monteringen skal gjennomføres av autoriserte installatører, og installasjonsanvisningen samt gjeldende forskrifter skal følges.

[pl] Ważne wskazówki dotyczące instalacji/montażu

Instalację/montaż powinien wykonać specjalista uprawniony do tego typu prac z uwzględnieniem informacji podanych w niniejszej instrukcji oraz aktualnie obowiązujących przepisów.

[pt] Indicações importantes relativas à instalação/montagem

A instalação/montagem deve ser efectuada por um técnico autorizado para os trabalhos, respeitando este manual e as prescrições válidas.

[ro] Indicații importante privind instalarea/montajul

Instalarea/montajul trebuie realizate de către un specialist autorizat pentru lucrările respective, respectându-se prezentele instrucțiuni și prescripțiile valabile.

[ru] Важные указания по подключению/монтажу

Подключение/монтаж должны выполнять только специалисты, имеющие допуск к выполнению таких работ, при соблюдении требований этой инструкции и действующих норм и правил.

[sk] Dôležité pokyny týkajúce sa inštalácie/montáže

Inštaláciu/montáž musí vykonať odborný personál, ktorý má oprávnenie pre výkon týchto prác, pričom musí dodržiavať pokyny uvedené v tomto návode a platné predpisy.

[sl] Pomembni napotki za namestitvev/montažo

Inštalacijo/montažo lahko izvede samo pooblaščen strokovnjak ob upoštevanju teh navodil in veljavnih predpisov.

[sr] Važna uputstva za ugradnju i montažu

Ovu instalaciju/montažu moraju da obave stručna lica koja su ovlašćena za obavljanje takvih radova u skladu sa ovim uputstvom i važećim propisima.

[sv] Viktiga anvisningar för installation/montering

Installationen/monteringen måste utföras av en behörig och tekniskt utbildad person enligt denna anvisning samt gällande föreskrifter.

[tr] Kurulum/Montaj ile ilgili önemli uyarılar

Kurulum/montaj, bu çalışmalarını yapmasına müsaade edilen uzman kişiler tarafından işbu kılavuz ve geçerli yönetmelikler dikkate alınarak yapılmalıdır.

[uk] Важливі вказівки щодо установки/монтажу

Встановлення/монтаж повинні виконувати фахівці, що допущені до виконання таких робіт, із дотриманням цієї інструкції та діючих приписів.

[zh] 安装方面的重要提示

安装和组装工作必须由经过许可的专业人员进行, 同时必须遵守本说明书和现行法规的相关要求

[ar] ملاحظات هامة للتركيب/التجميع
يجب أن يتم التركيب/التجميع من قبل متخصص مصرح له بالعمل، مع مراعاة اللوائح السارية.

[fa] تذکرات مهم درباره نصب/مونتاژ
نصب/مونتاژ باید توسط فردی حرفه ای که مجاز به انجام این کار است، و همچنین با توجه کامل به مقررات مربوطه انجام شود.

[az] Quraşdırılma

Quraşdırılma işinin yerinə yetirilməsi səlahiyyətli bir mütəxəssis tərəfindən və müvafiq qaydalara uyğun olaraq aparılmalıdır.

Inhaltsverzeichnis Table of contents	Table de matieres Indice	Inhoud Indice
AGS10 MS100-2	7735600057	5
AGS10 MS200-2	7735600058	7
AGS10 TDS100-2	7735600059	9
AGS10-2	7735600055	11
AGS10-2	7735600056	12
AGS10E-2	7735600054	13
AGS20-2	7735600060	14
AGS50-2	7735600061	15
TDS100-2	7735600067	16
TDS100-2	7735600068	17
WMZ 10-2	7735600127	18
WMZ 15-2	7735600128	19
WMZ 5-2	7735600126	20

Ersatzteilliste
Spare parts list
Liste des pièces de rechange
Lista parti di ricambio
Lista de repuestos
Catálogo de peças de substituição

AGS10 MS100-2 - 7735600057

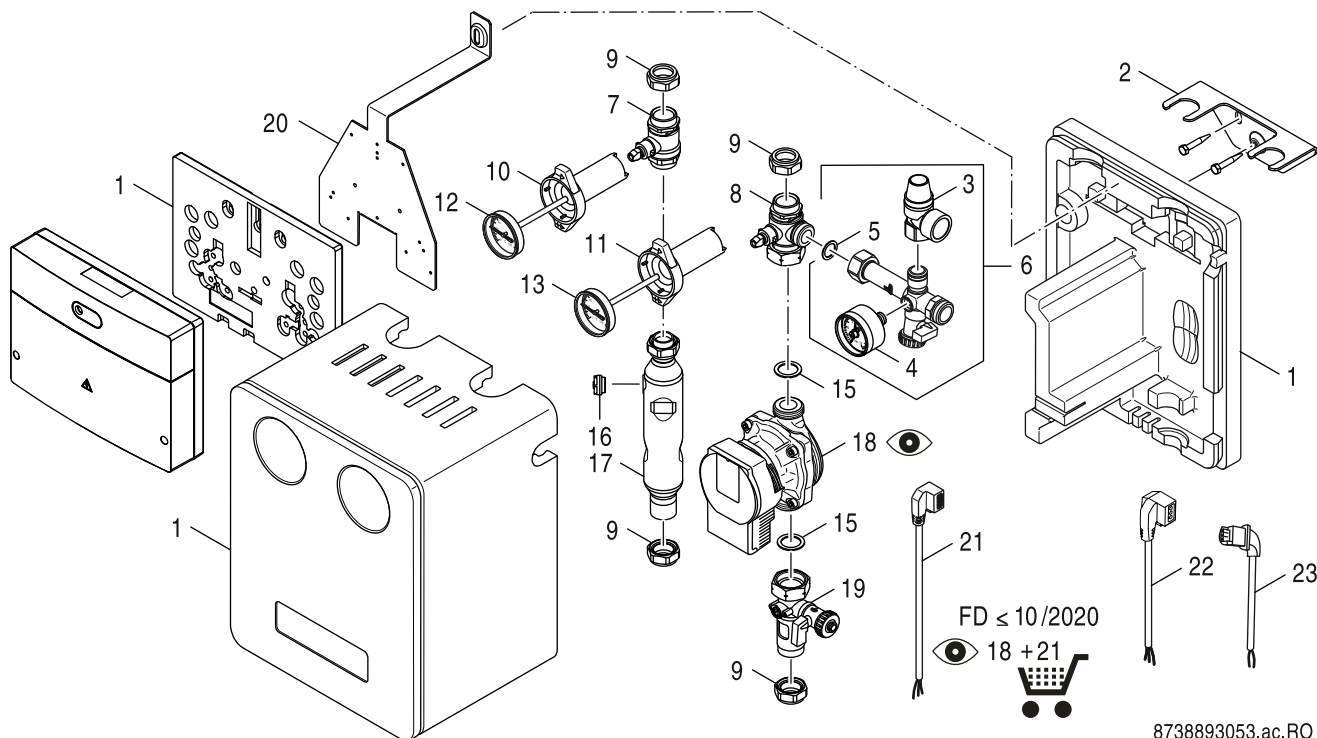

8738893053.ac.RO

	Bestell-Nr.	Bezeichnung	Description	Dénomination	Descrizioni	Descripción	Designação
1	8 735 300 263	Isolierung	Insulation	Isolation	Coibentazione	Aislamiento	Isolamento
2	8 735 300 267	Halter (10 & 20)	Holder (10 & 20)	Support (10 & 20)	Supporto (10 & 20)	Soporte (10 & 20)	Suporte (10 & 20)
3	8 718 221 470 0	Sicherheitsventil 6 bar DN15	Safety relief valve 6 bar DN15	SOUPAPE DE SECURITE 6 BAR DN15	Valvola sicurezza 6 bar DN15	Válvula de sobrepresión 6 bar DN15	Válvula de segurança 6 bar DN15
4	8 735 300 266	Manometer 10 bar, 1/4"	Pressure gauge 10 bar, 1/4"	Manomètre 10 bar, 1/4"	Manometro 10 bar, 1/4"	Manómetro 10 bar, 1/4"	Manómetro
5	8 718 221 473 0	Dichtung 24 x 17 x 2 mm (2x)	Seal 24 x 17 x 2 mm (2x)	Joint 24 x 17 x 2 mm (2x)	Guarnizione 24 x 17 x 2 mm (2x)	Junta 24 x 17 x 2 mm (2x)	Vedante 24 x 17 x 2 mm (2x)
6	8 735 300 259	Sicherheitsgruppe (10 & 20)	Safety assembly (10 & 20)	Groupe de sécurité (10 & 20)	Gruppo sicurezze (10 & 20)	Grupo de seguridad (10 & 20)	Módulo de segurança (10 & 20)
7	7 735 600 309	Kugelhahn	Ball valve	Robinet à boule	Valvola a sfera	Válvula	Válvula de esfera
8	7 735 600 310	Kugelhahn	Ball valve	Robinet à boule	Valvola a sfera	Válvula	Válvula de esfera
9	7 735 600 313	Verschraubung 22mm (2x)	Connection union 22mm (2x)	RACC SONDE SANITAIRE 22MM (2x)	Raccordo 22mm (2x)	Racor 22mm (2x)	União roscada 22mm (2x)
9	8 735 300 339	Verschraubung 15mm (2x)	Screw fitting 15mm (2x)	Raccord sonde sanitaire 15mm (2x)	Connessioni giuntate 15mm (2x)	Unión roscada 15mm (2x)	União roscada 15mm (2x)
10	7 735 600 314	Griff rot 92mm	Handle red 92mm	Manette rouge 92mm	Manopola rosso 92mm	Mando del grifo rojo 92mm	Manípulo vermelho 92mm
11	7 735 600 315	Griff blau 92mm	Handle blue 92mm	Manette bleue 92mm	Manopola blu 92mm	Llave de corte azul 92mm	Manete do termometro azul 92mm
12	8 735 300 264	Thermometer (10 & 20) rot	Thermometer (10 & 20) red	Thermomètre (10 & 20) rouge	Termometro (10 & 20) rosso	Termómetro (10 & 20) rojo	Termómetro (10 & 20) vermelho
13	8 735 300 265	Thermometer (10 & 20) blau	Thermometer (10 & 20) blue	Thermomètre (10 & 20) bleu	Termometro (10 & 20) blu	Termómetro (10 & 20) azul	Termómetro (10 & 20) azul
15	8 735 300 261	Dichtung 30x21x2 (2x) everp	Gasket 30x21x2 (2x) sp	Joint 30x21x2 (2x)	Guarnizione 30x21x2 (2x)	Junta 30x21x2 (2x)	Vedação 30x21x2 (2x)
16	8 718 221 485 0	Stopfen 3/8" 150°C	Grommet 3/8" 150°C	Bouchon 3/8" 150°C	Coperchietto 3/8" 150°C	Tapon 3/8" 150°C	Bujão 3/8" 150°C
17	8 718 224 984 0	Luftabscheider	air separator	séparateur air 2-16l/min1"FLxM28 1	Separatore aria con 2-16l/min1"FLxM28 1	separador de aire	separador de ar 2-16l/min1"FLxM28 1.
18	8 735 300 759	Pumpe Para ST 15-130/7-50/iPWM2-6	Pump Para ST 15-130/7-50/iPWM2-6	Pompe Para ST 15-130/7-75/iPWM2-6	Circolatore Para ST 15-130/7-75/iPWM2-6	Bomba Para ST 15-130/7-75/iPWM2-6	Bomba Para ST 15-130/7-75/iPWM2-6
19	8 718 530 658 0	Durchflussbegrenzer	flow limiter	Limiteur de débit	Regolatore di flusso	limitador de caudal	limitador de fluxo
20	8 735 300 268	Halter Regler	Holder controller	Support régulateur	Supporto regolatore	Soporte aparato de regulación	Suporte regulador
20	8 735 300 762	Kabel Pumpe 230V 2,5m PR60 everp	Cable pump 230V 2,5m PR60 packed	Câble pompe 230V 2,5m PR60	Cavo Pompa 230V 2,5m PR60	Cables bomba 230V 2,5m PR60	Cabo bomba 230V 2,5m PR60
22	8 735 300 269	Kabel Pumpe 2,5m 230V everp	Cable pump 2,5m 230V	Câble pompe 2,5m 230V	Cavo Pompa 2,5m 230V	Cables bomba 2,5m 230V	Cabo bomba 2,5m 230V
23	8 735 300 270	Kabel 2,5m PWM	Cable 2,5m PWM	Câble 2,5m PWM	Cavo 2,5m PWM	Cables 2,5m PWM	Cabo 2,5m PWM

Ersatzteilliste
 Spare parts list
 Liste des pièces de rechange
 Lista parti di ricambio
 Lista de repuestos
 Catálogo de peças de substituição

AGS10 MS100-2 - 7735600057

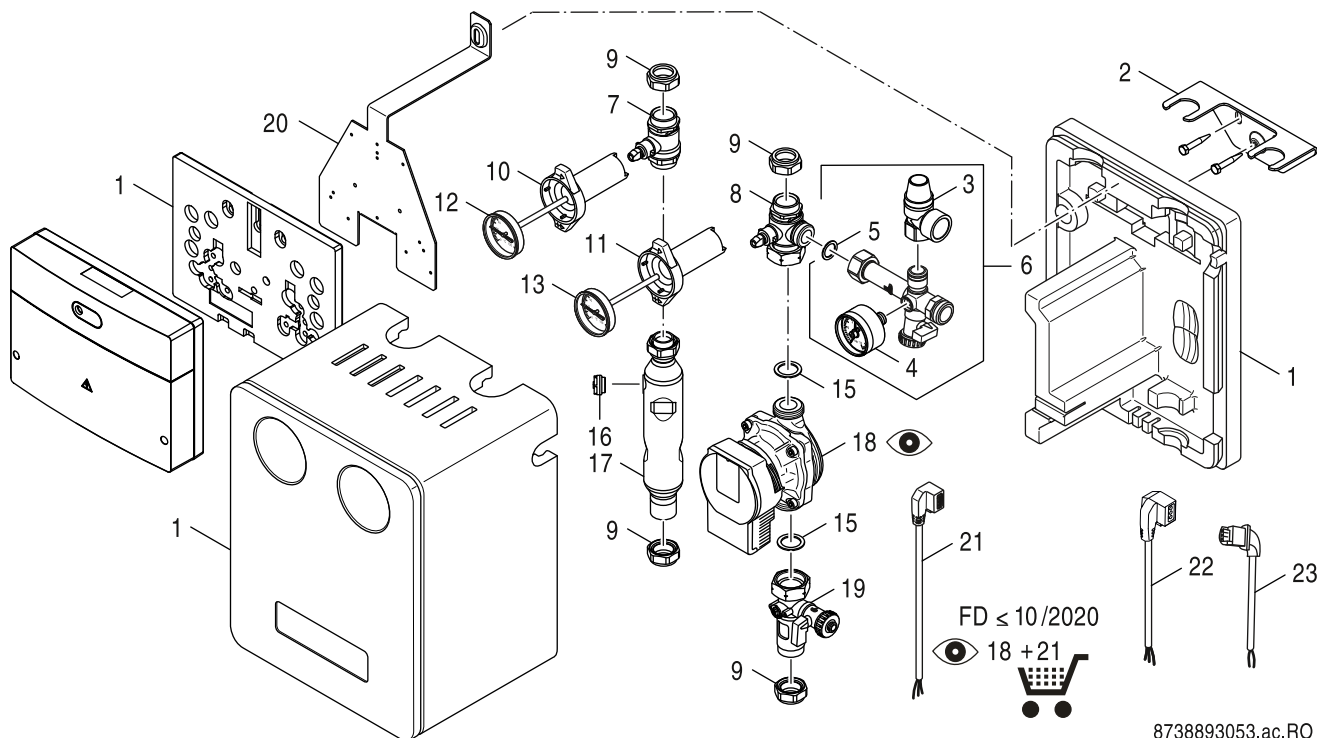

Bestell-Nr.	Bezeichnung	Description	Dénomination	Descrizioni	Descripción	Designação
7 738 110 122	MS100 Brandless PL, CZ, DK, GR, TR, SK,	MS100 Brandless PL, CZ, DK, GR, TR, SK,	Module MS 100	Modulo solare MS 100 EMS plus	Modul MS100 Brandless	Modul MS 100 Brandless

Ersatzteilliste
Spare parts list
Liste des pièces de rechange
Lista parti di ricambio
Lista de repuestos
Catálogo de peças de substituição

AGS10 MS200-2 - 7735600058

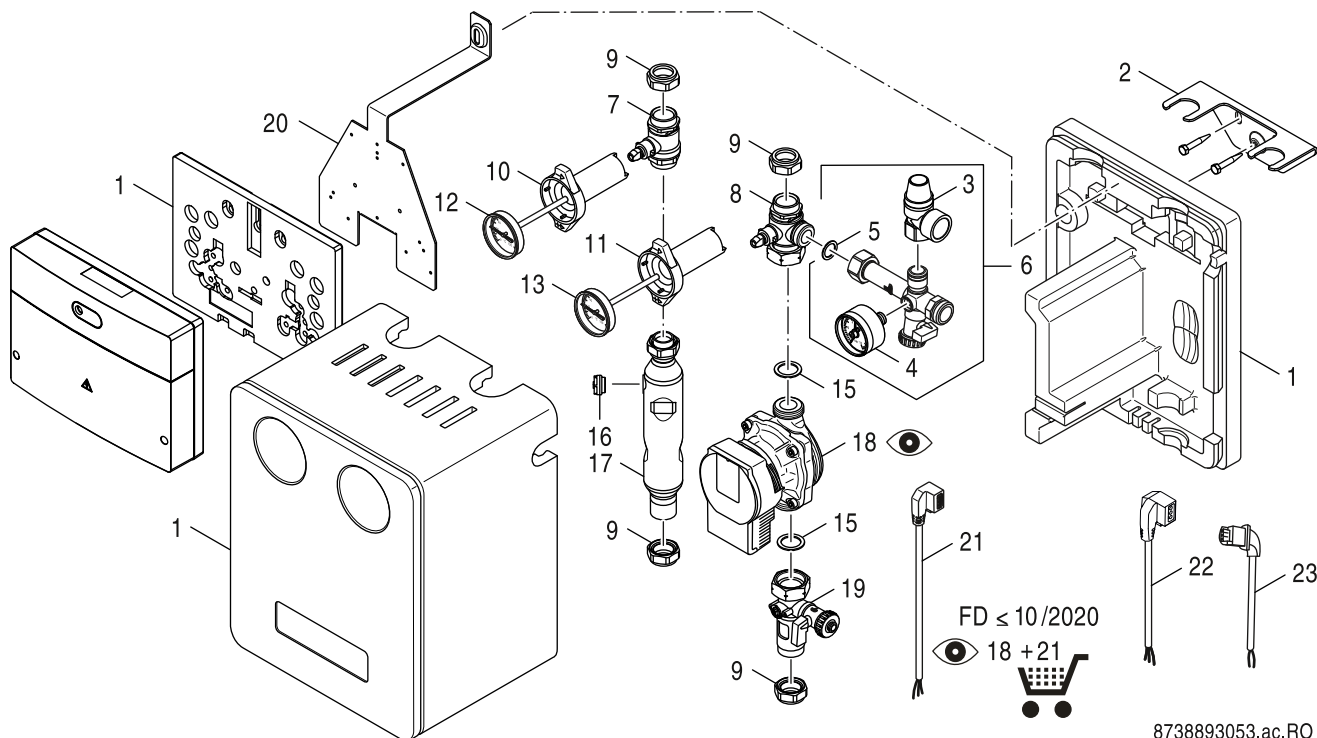

8738893053.ac.RO

	Bestell-Nr.	Bezeichnung	Description	Dénomination	Descrizioni	Descripción	Designação
1	8 735 300 263	Isolierung	Insulation	Isolation	Coibentazione	Aislamiento	Isolamento
2	8 735 300 267	Halter (10 & 20)	Holder (10 & 20)	Support (10 & 20)	Supporto (10 & 20)	Soporte (10 & 20)	Suporte (10 & 20)
3	8 718 221 470 0	Sicherheitsventil 6 bar DN15	Safety relief valve 6 bar DN15	SOUPAPE DE SECURITE 6 BAR DN15	Valvola sicurezza 6 bar DN15	Válvula de sobrepresión 6 bar DN15	Válvula de segurança 6 bar DN15
4	8 735 300 266	Manometer 10 bar, 1/4"	Pressure gauge 10 bar, 1/4"	Manomètre 10 bar, 1/4"	Manometro 10 bar, 1/4"	Manómetro 10 bar, 1/4"	Manómetro
5	8 718 221 473 0	Dichtung 24 x 17 x 2 mm (2x)	Seal 24 x 17 x 2 mm (2x)	Joint 24 x 17 x 2 mm (2x)	Guarnizione 24 x 17 x 2 mm (2x)	Junta 24 x 17 x 2 mm (2x)	Vedante 24 x 17 x 2 mm (2x)
6	8 735 300 259	Sicherheitsgruppe (10 & 20)	Safety assembly (10 & 20)	Groupe de sécurité (10 & 20)	Gruppo sicurezze (10 & 20)	Grupo de seguridad (10 & 20)	Módulo de segurança (10 & 20)
7	7 735 600 309	Kugelhahn	Ball valve	Robinet à boule	Valvola a sfera	Válvula	Válvula de esfera
8	7 735 600 310	Kugelhahn	Ball valve	Robinet à boule	Valvola a sfera	Válvula	Válvula de esfera
9	7 735 600 313	Verschraubung 22mm (2x)	Connection union 22mm (2x)	RACC SONDE SANITAIRE 22MM (2x)	Raccordo 22mm (2x)	Racor 22mm (2x)	União roscada 22mm (2x)
9	8 735 300 339	Verschraubung 15mm (2x)	Screw fitting 15mm (2x)	Raccord sonde sanitaire 15mm (2x)	Connessioni giuntate 15mm (2x)	Unión roscada 15mm (2x)	União roscada 15mm (2x)
10	7 735 600 314	Griff rot 92mm	Handle red 92mm	Manette rouge 92mm	Manopola rosso 92mm	Mando del grifo rojo 92mm	Manípulo vermelho 92mm
11	7 735 600 315	Griff blau 92mm	Handle blue 92mm	Manette bleue 92mm	Manopola blu 92mm	Llave de corte azul 92mm	Manete do termometro azul 92mm
12	8 735 300 264	Thermometer (10 & 20) rot	Thermometer (10 & 20) red	Thermomètre (10 & 20) rouge	Termometro (10 & 20) rosso	Termómetro (10 & 20) rojo	Termómetro (10 & 20) vermelho
13	8 735 300 265	Thermometer (10 & 20) blau	Thermometer (10 & 20) blue	Thermomètre (10 & 20) bleu	Termometro (10 & 20) blu	Termómetro (10 & 20) azul	Termómetro (10 & 20) azul
15	8 735 300 261	Dichtung 30x21x2 (2x) everp	Gasket 30x21x2 (2x) sp	Joint 30x21x2 (2x)	Guarnizione 30x21x2 (2x)	Junta 30x21x2 (2x)	Vedação 30x21x2 (2x)
16	8 718 221 485 0	Stopfen 3/8" 150°C	Grommet 3/8" 150°C	Bouchon 3/8" 150°C	Coperchietto 3/8" 150°C	Tapon 3/8" 150°C	Bujão 3/8" 150°C
17	8 718 224 984 0	Luftabscheider	air separator	séparateur air 2-16l/min1"FLxM28 1	Separatore aria con 2-16l/min1"FLxM28 1	separador de aire	separador de ar 2-16l/min1"FLxM28 1.
18	8 735 300 759	Pumpe Para ST 15-130/7-50/iPWM2-6	Pump Para ST 15-130/7-50/iPWM2-6	Pompe Para ST 15-130/7-75/iPWM2-6	Circolatore Para ST 15-130/7-75/iPWM2-6	Bomba Para ST 15-130/7-75/iPWM2-6	Bomba Para ST 15-130/7-75/iPWM2-6
19	8 718 530 658 0	Durchflussbegrenzer	flow limiter	Limiteur de débit	Regolatore di flusso	limitador de caudal	limitador de fluxo
20	8 735 300 268	Halter Regler	Holder controller	Support régulateur	Supporto regolatore	Soporte aparato de regulación	Suporte regulador
20	8 735 300 762	Kabel Pumpe 230V 2,5m PR60 everp	Cable pump 230V 2,5m PR60 packed	Câble pompe 230V 2,5m PR60	Cavo Pompa 230V 2,5m PR60	Cables bomba 230V 2,5m PR60	Cabo bomba 230V 2,5m PR60
22	8 735 300 269	Kabel Pumpe 2,5m 230V everp	Cable pump 2,5m 230V	Câble pompe 2,5m 230V	Cavo Pompa 2,5m 230V	Cables bomba 2,5m 230V	Cabo bomba 2,5m 230V
23	8 735 300 270	Kabel 2,5m PWM	Cable 2,5m PWM	Câble 2,5m PWM	Cavo 2,5m PWM	Cables 2,5m PWM	Cabo 2,5m PWM

Ersatzteilliste
 Spare parts list
 Liste des pièces de rechange
 Lista parti di ricambio
 Lista de repuestos
 Catálogo de peças de substituição

AGS10 MS200-2 - 7735600058

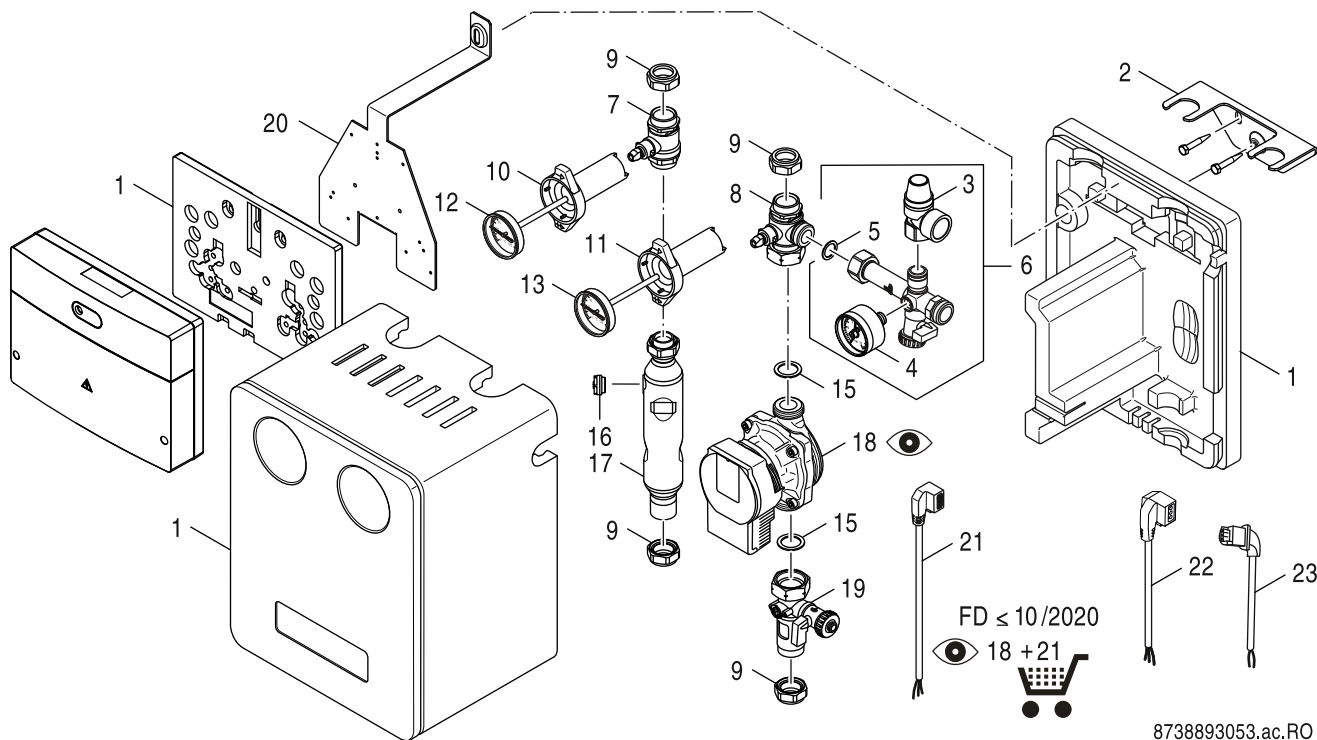

Bestell-Nr.	Bezeichnung	Description	Dénomination	Descrizioni	Descripción	Designação
7 738 101 059	MS200 TR, PL, CZ etc.	MS200 TR, PL, CZ etc.				

Ersatzteilliste
Spare parts list
Liste des pièces de rechange
Lista parti di ricambio
Lista de repuestos
Catálogo de peças de substituição

AGS10 TDS100-2 - 7735600059

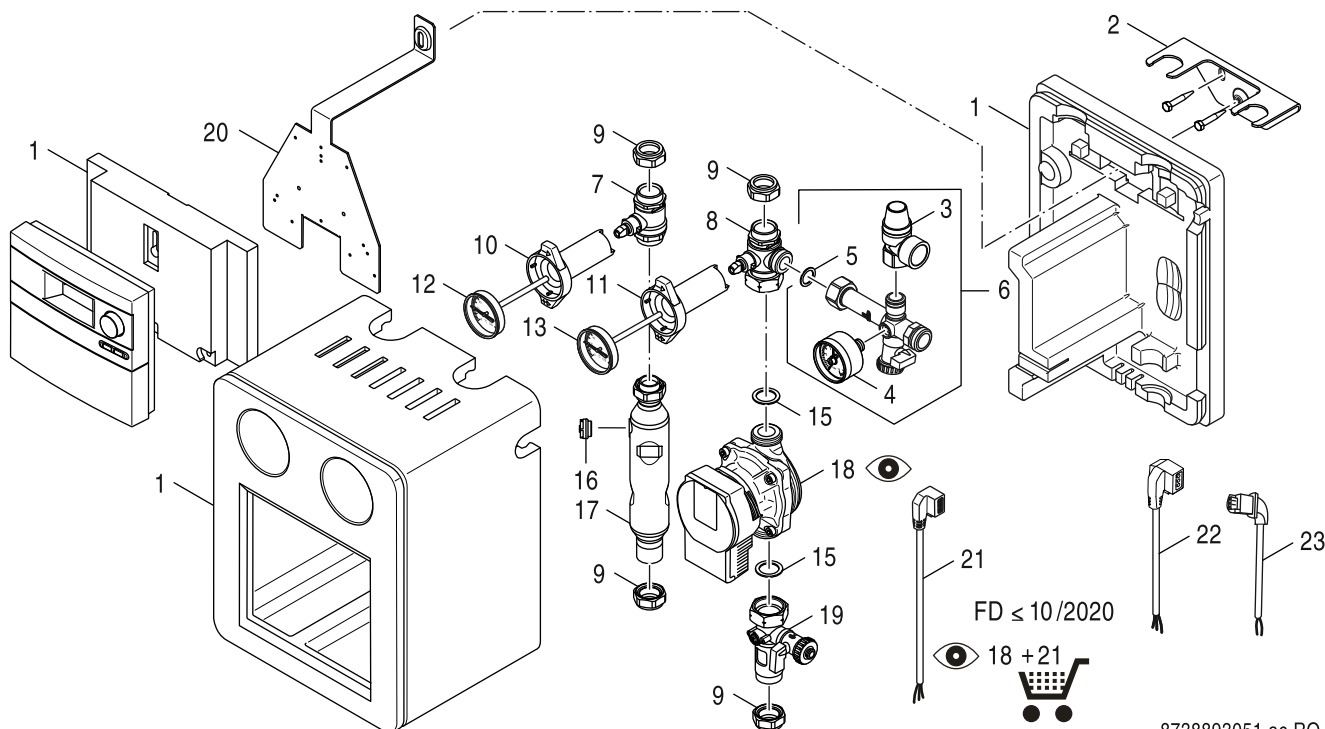

8738893051.ac.RO

	Bestell-Nr.	Bezeichnung	Description	Dénomination	Descrizioni	Descripción	Designação
1	8 735 300 271	Isolierung	Insulation	Isolation	Coibentazione	Aislamiento	Isolamento
2	8 735 300 267	Halter (10 & 20)	Holder (10 & 20)	Support (10 & 20)	Supporto (10 & 20)	Soporte (10 & 20)	Suporte (10 & 20)
3	8 718 221 470 0	Sicherheitsventil 6 bar DN15	Safety relief valve 6 bar DN15	SOUPAPE DE SECURITE 6 BAR DN15	Valvola sicurezza 6 bar DN15	Válvula de sobrepresión 6 bar DN15	Válvula de segurança 6 bar DN15
4	8 735 300 266	Manometer 10 bar, 1/4"	Pressure gauge 10 bar, 1/4"	Manomètre 10 bar, 1/4"	Manometro 10 bar, 1/4"	Manómetro 10 bar, 1/4"	Manómetro
5	8 718 221 473 0	Dichtung 24 x 17 x 2 mm (2x)	Seal 24 x 17 x 2 mm (2x)	Joint 24 x 17 x 2 mm (2x)	Guarnizione 24 x 17 x 2 mm (2x)	Junta 24 x 17 x 2 mm (2x)	Vedante 24 x 17 x 2 mm (2x)
6	8 735 300 259	Sicherheitsgruppe (10 & 20)	Safety assembly (10 & 20)	Groupe de sécurité (10 & 20)	Gruppo sicurezze (10 & 20)	Grupo de seguridad (10 & 20)	Módulo de segurança (10 & 20)
7	7 735 600 309	Kugelhahn	Ball valve	Robinet à boule	Valvola a sfera	Válvula	Válvula de esfera
8	7 735 600 310	Kugelhahn	Ball valve	Robinet à boule	Valvola a sfera	Válvula	Válvula de esfera
9	7 735 600 313	Verschraubung 22mm (2x)	Connection union 22mm (2x)	RACC SONDE SANITAIRE 22MM (2x)	Raccordo 22mm (2x)	Racor 22mm (2x)	União roscada 22mm (2x)
9	8 735 300 339	Verschraubung 15mm (2x)	Screw fitting 15mm (2x)	Raccord sonde sanitaire 15mm (2x)	Connessioni giuntate 15mm (2x)	Unión roscada 15mm (2x)	União roscada 15mm (2x)
10	7 735 600 314	Griff rot 92mm	Handle red 92mm	Manette rouge 92mm	Manopola rosso 92mm	Mando del grifo rojo 92mm	Manípulo vermelho 92mm
11	7 735 600 315	Griff blau 92mm	Handle blue 92mm	Manette bleue 92mm	Manopola blu 92mm	Llave de corte azul 92mm	Manete do termometro azul 92mm
12	8 735 300 264	Thermometer (10 & 20) rot	Thermometer (10 & 20) red	Thermomètre (10 & 20) rouge	Termometro (10 & 20) rosso	Termómetro (10 & 20) rojo	Termómetro (10 & 20) vermelho
13	8 735 300 265	Thermometer (10 & 20) blau	Thermometer (10 & 20) blue	Thermomètre (10 & 20) bleu	Termometro (10 & 20) blu	Termómetro (10 & 20) azul	Termómetro (10 & 20) azul
15	8 735 300 261	Dichtung 30x21x2 (2x) everp	Gasket 30x21x2 (2x) sp	Joint 30x21x2 (2x)	Guarnizione 30x21x2 (2x)	Junta 30x21x2 (2x)	Vedação 30x21x2 (2x)
16	8 718 221 485 0	Stopfen 3/8" 150°C	Grommet 3/8" 150°C	Bouchon 3/8" 150°C	Coperchietto 3/8" 150°C	Tapon 3/8" 150°C	Bujão 3/8" 150°C
17	8 718 224 984 0	Luftabscheider	air separator	séparateur air 2-16l/min1"FLxM28 1	Separatore aria con 2-16l/min1"FLxM28 1	separador de aire	separador de ar 2-16l/min1"FLxM28 1.
18	8 735 300 759	Pumpe Para ST 15-130/7-50/iPWM2-6	Pump Para ST 15-130/7-50/iPWM2-6	Pompe Para ST 15-130/7-75/iPWM2-6	Circolatore Para ST 15-130/7-75/iPWM2-6	Bomba Para ST 15-130/7-75/iPWM2-6	Bomba Para ST 15-130/7-75/iPWM2-6
19	8 718 530 658 0	Durchflussbegrenzer	flow limiter	Limiteur de débit	Regolatore di flusso	limitador de caudal	limitador de fluxo
20	8 735 300 268	Halter Regler	Holder controller	Support régulateur	Supporto regolatore	Soporte aparato de regulación	Suporte regulador
21	8 735 300 762	Kabel Pumpe 230V 2,5m PR60 everp	Cable pump 230V 2,5m PR60 packed	Câble pompe 230V 2,5m PR60	Cavo Pompa 230V 2,5m PR60	Cables bomba 230V 2,5m PR60	Cabo bomba 230V 2,5m PR60
22	8 735 300 269	Kabel Pumpe 2,5m 230V everp	Cable pump 2,5m 230V	Câble pompe 2,5m 230V	Cavo Pompa 2,5m 230V	Cables bomba 2,5m 230V	Cabo bomba 2,5m 230V
23	8 735 300 270	Kabel 2,5m PWM	Cable 2,5m PWM	Câble 2,5m PWM	Cavo 2,5m PWM	Cables 2,5m PWM	Cabo 2,5m PWM

Ersatzteilliste
 Spare parts list
 Liste des pièces de rechange
 Lista parti di ricambio
 Lista de repuestos
 Catálogo de peças de substituição

AGS10 TDS100-2 - 7735600059

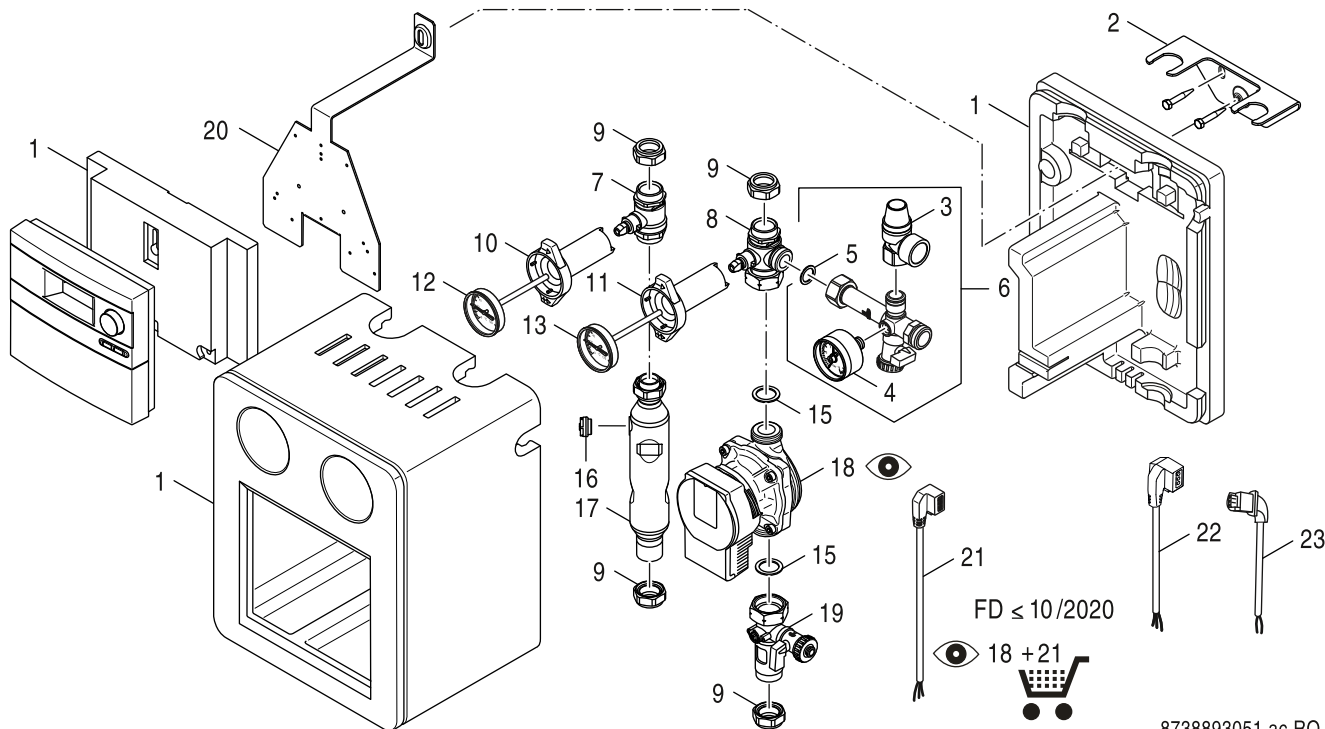

8738893051.ac.RO

Bestell-Nr.	Bezeichnung	Description	Dénomination	Descrizioni	Descripción	Designação
7 735 600 068	Regler Solar TDS100-2	control solar TDS100-2	Controlador Sola TDS 100-2	control solar TDS100-2		

Ersatzteilliste
Spare parts list
Liste des pièces de rechange
Lista parti di ricambio
Lista de repuestos
Catálogo de peças de substituição

AGS10-2 - 7735600055

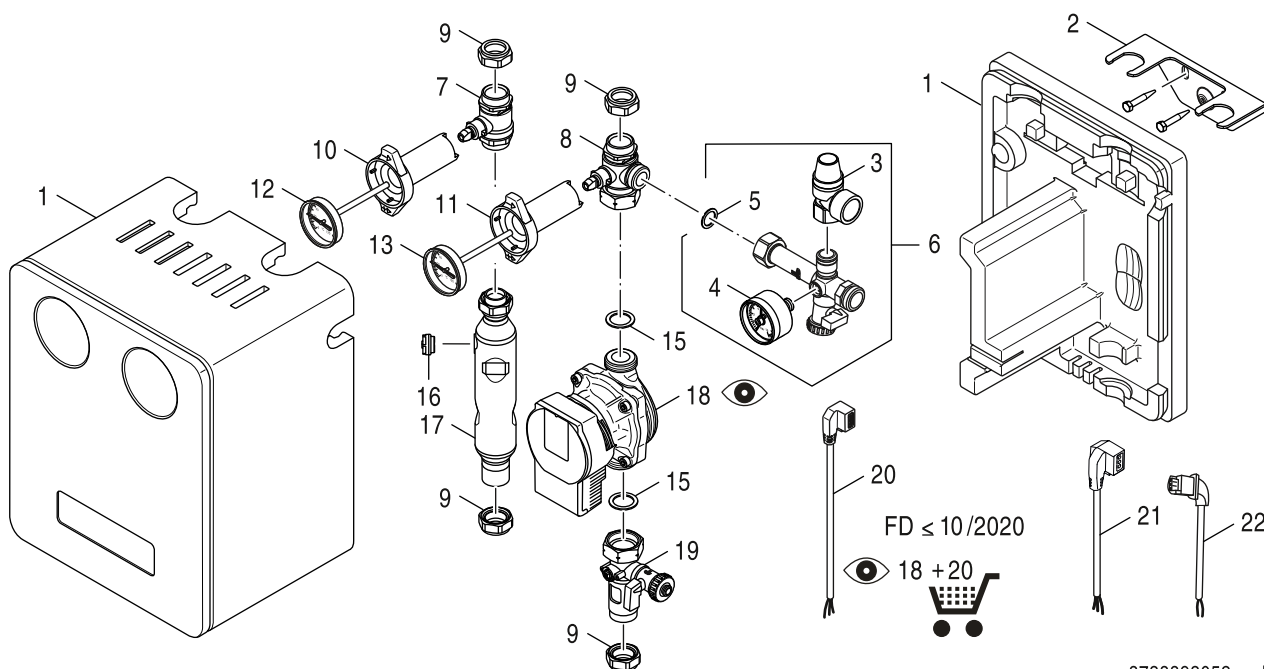

8738893052.ac.RO

	Bestell-Nr.	Bezeichnung	Description	Dénomination	Descrizioni	Descripción	Designação
1	8 735 300 263	Isolierung	Insulation	Isolation	Coibentazione	Aislamiento	Isolamento
2	8 735 300 267	Halter (10 & 20)	Holder (10 & 20)	Support (10 & 20)	Supporto (10 & 20)	Soporte (10 & 20)	Suporte (10 & 20)
3	8 718 221 470 0	Sicherheitsventil 6 bar DN15	Safety relief valve 6 bar DN15	SOUPAPE DE SECURITE 6 BAR DN15	Valvola sicurezza 6 bar DN15	Válvula de sobrepresión 6 bar DN15	Válvula de segurança 6 bar DN15
4	8 735 300 266	Manometer 10 bar, 1/4"	Pressure gauge 10 bar, 1/4"	Manomètre 10 bar, 1/4"	Manometro 10 bar, 1/4"	Manómetro 10 bar, 1/4"	Manómetro
5	8 718 221 473 0	Dichtung 24 x 17 x 2 mm (2x)	Seal 24 x 17 x 2 mm (2x)	Joint 24 x 17 x 2 mm (2x)	Guarnizione 24 x 17 x 2 mm (2x)	Junta 24 x 17 x 2 mm (2x)	Vedante 24 x 17 x 2 mm (2x)
6	8 735 300 259	Sicherheitsgruppe (10 & 20)	Safety assembly (10 & 20)	Groupe de sécurité (10 & 20)	Gruppo sicurezze (10 & 20)	Grupo de seguridad (10 & 20)	Módulo de segurança (10 & 20)
7	7 735 600 309	Kugelhahn	Ball valve	Robinet à boule	Valvola a sfera	Válvula	Válvula de esfera
8	7 735 600 310	Kugelhahn	Ball valve	Robinet à boule	Valvola a sfera	Válvula	Válvula de esfera
9	7 735 600 313	Verschraubung 22mm (2x)	Connection union 22mm (2x)	RACC SONDE SANITAIRE 22MM (2x)	Raccordo 22mm (2x)	Racor 22mm (2x)	União roscada 22mm (2x)
9	8 735 300 339	Verschraubung 15mm (2x)	Screw fitting 15mm (2x)	Raccord sonde sanitaire 15mm (2x)	Connessioni giuntate 15mm (2x)	Unión roscada 15mm (2x)	União roscada 15mm (2x)
10	7 735 600 314	Griff rot 92mm	Handle red 92mm	Manette rouge 92mm	Manopola rosso 92mm	Mando del grifo rojo 92mm	Manípulo vermelho 92mm
11	7 735 600 315	Griff blau 92mm	Handle blue 92mm	Manette bleue 92mm	Manopola blu 92mm	Llave de corte azul 92mm	Manete do termometro azul 92mm
12	8 735 300 264	Thermometer (10 & 20) rot	Thermometer (10 & 20) red	Thermomètre (10 & 20) rouge	Termometro (10 & 20) rosso	Termómetro (10 & 20) rojo	Termómetro (10 & 20) vermelho
13	8 735 300 265	Thermometer (10 & 20) blau	Thermometer (10 & 20) blue	Thermomètre (10 & 20) bleu	Termometro (10 & 20) blu	Termómetro (10 & 20) azul	Termómetro (10 & 20) azul
15	8 735 300 261	Dichtung 30x21x2 (2x) everp	Gasket 30x21x2 (2x) sp	Joint 30x21x2 (2x)	Guarnizione 30x21x2 (2x)	Junta 30x21x2 (2x)	Vedação 30x21x2 (2x)
16	8 718 221 485 0	Stopfen 3/8" 150°C	Grommet 3/8" 150°C	Bouchon 3/8" 150°C	Coperchietto 3/8" 150°C	Tapon 3/8" 150°C	Bujão 3/8" 150°C
17	8 718 224 984 0	Luftabscheider	air separator	séparateur air 2-16l/min1"FLxM28 1	Separatore aria con 2-16l/min1"FLxM28 1	separador de aire	separador de ar 2-16l/min1"FLxM28 1.
18	8 735 300 759	Pumpe Para ST 15-130/7-50/iPWM2-6	Pump Para ST 15-130/7-50/iPWM2-6	Pompe Para ST 15-130/7-75/iPWM2-6	Circolatore Para ST 15-130/7-75/iPWM2-6	Bomba Para ST 15-130/7-75/iPWM2-6	Bomba Para ST 15-130/7-75/iPWM2-6
19	8 718 530 658 0	Durchflussbegrenzer	flow limiter	Limiteur de débit	Regolatore di flusso	limitador de caudal	limitador de fluxo
20	8 735 300 762	Kabel Pumpe 230V 2,5m PR60 everp	Cable pump 230V 2,5m PR60 packed	Câble pompe 230V 2,5m PR60	Cavo Pompa 230V 2,5m PR60	Cables bomba 230V 2,5m PR60	Cabo bomba 230V 2,5m PR60
21	8 735 300 269	Kabel Pumpe 2,5m 230V everp	Cable pump 2,5m 230V	Câble pompe 2,5m 230V	Cavo Pompa 2,5m 230V	Cables bomba 2,5m 230V	Cabo bomba 2,5m 230V
22	8 735 300 270	Kabel 2,5m PWM	Cable 2,5m PWM	Câble 2,5m PWM	Cavo 2,5m PWM	Cables 2,5m PWM	Cabo 2,5m PWM

Ersatzteilliste
Spare parts list
Liste des pièces de rechange
Lista parti di ricambio
Lista de repuestos
Catálogo de peças de substituição

AGS10-2 - 7735600056

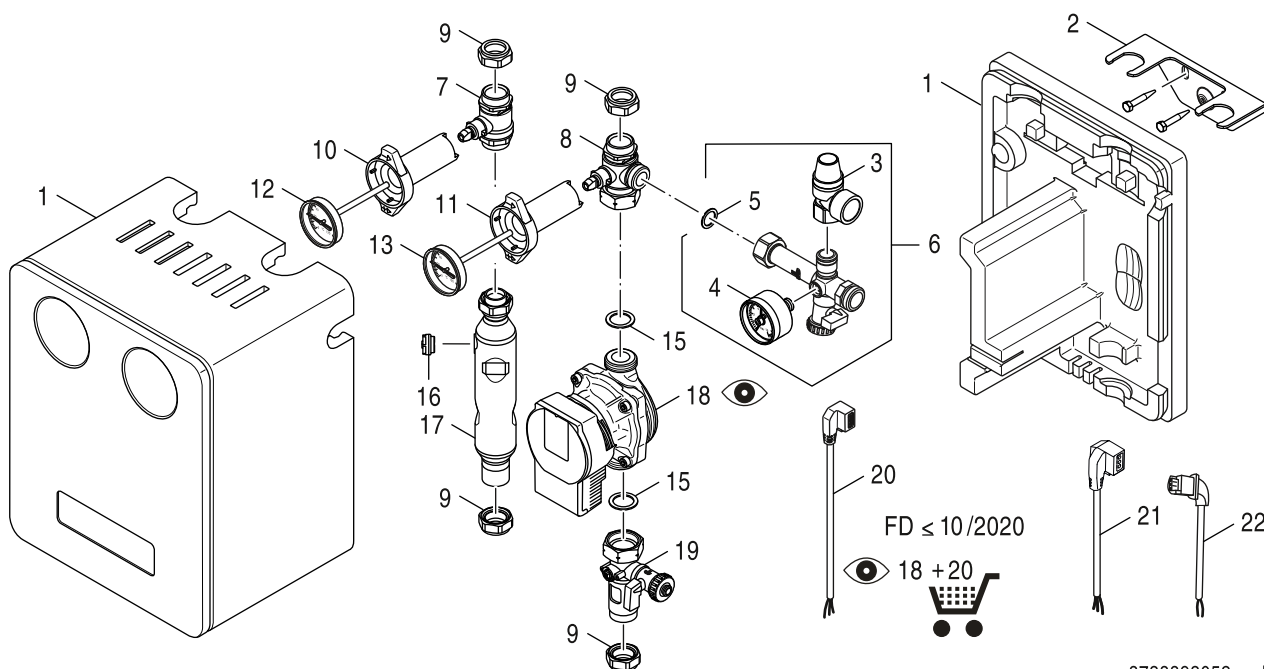

8738893052.ac.RO

	Bestell-Nr.	Bezeichnung	Description	Dénomination	Descrizioni	Descripción	Designação
1	8 735 300 263	Isolierung	Insulation	Isolation	Coibentazione	Aislamiento	Isolamento
2	8 735 300 267	Halter (10 & 20)	Holder (10 & 20)	Support (10 & 20)	Supporto (10 & 20)	Soporte (10 & 20)	Suporte (10 & 20)
3	8 718 221 470 0	Sicherheitsventil 6 bar DN15	Safety relief valve 6 bar DN15	SOUPAPE DE SECURITE 6 BAR DN15	Valvola sicurezza 6 bar DN15	Válvula de sobrepresión 6 bar DN15	Válvula de segurança 6 bar DN15
4	8 735 300 266	Manometer 10 bar, 1/4"	Pressure gauge 10 bar, 1/4"	Manomètre 10 bar, 1/4"	Manometro 10 bar, 1/4"	Manómetro 10 bar, 1/4"	Manómetro
5	8 718 221 473 0	Dichtung 24 x 17 x 2 mm (2x)	Seal 24 x 17 x 2 mm (2x)	Joint 24 x 17 x 2 mm (2x)	Guarnizione 24 x 17 x 2 mm (2x)	Junta 24 x 17 x 2 mm (2x)	Vedante 24 x 17 x 2 mm (2x)
6	8 735 300 259	Sicherheitsgruppe (10 & 20)	Safety assembly (10 & 20)	Groupe de sécurité (10 & 20)	Gruppo sicurezze (10 & 20)	Grupo de seguridad (10 & 20)	Módulo de segurança (10 & 20)
7	7 735 600 309	Kugelhahn	Ball valve	Robinet à boule	Valvola a sfera	Válvula	Válvula de esfera
8	7 735 600 310	Kugelhahn	Ball valve	Robinet à boule	Valvola a sfera	Válvula	Válvula de esfera
9	7 735 600 313	Verschraubung 22mm (2x)	Connection union 22mm (2x)	RACC SONDE SANITAIRE 22MM (2x)	Raccordo 22mm (2x)	Racor 22mm (2x)	União roscada 22mm (2x)
9	8 735 300 339	Verschraubung 15mm (2x)	Screw fitting 15mm (2x)	Raccord sonde sanitaire 15mm (2x)	Connessioni giuntate 15mm (2x)	Unión roscada 15mm (2x)	União roscada 15mm (2x)
10	7 735 600 314	Griff rot 92mm	Handle red 92mm	Manette rouge 92mm	Manopola rosso 92mm	Mando del grifo rojo 92mm	Manípulo vermelho 92mm
11	7 735 600 315	Griff blau 92mm	Handle blue 92mm	Manette bleue 92mm	Manopola blu 92mm	Llave de corte azul 92mm	Manete do termometro azul 92mm
12	8 735 300 264	Thermometer (10 & 20) rot	Thermometer (10 & 20) red	Thermomètre (10 & 20) rouge	Termometro (10 & 20) rosso	Termómetro (10 & 20) rojo	Termómetro (10 & 20) vermelho
13	8 735 300 265	Thermometer (10 & 20) blau	Thermometer (10 & 20) blue	Thermomètre (10 & 20) bleu	Termometro (10 & 20) blu	Termómetro (10 & 20) azul	Termómetro (10 & 20) azul
15	8 735 300 261	Dichtung 30x21x2 (2x) everp	Gasket 30x21x2 (2x) sp	Joint 30x21x2 (2x)	Guarnizione 30x21x2 (2x)	Junta 30x21x2 (2x)	Vedação 30x21x2 (2x)
16	8 718 221 485 0	Stopfen 3/8" 150°C	Grommet 3/8" 150°C	Bouchon 3/8" 150°C	Coperchietto 3/8" 150°C	Tapon 3/8" 150°C	Bujão 3/8" 150°C
17	8 718 224 984 0	Luftabscheider	air separator	séparateur air 2-16l/min1"FLxM28 1	Separatore aria con 2-16l/min1"FLxM28 1	separador de aire	separador de ar 2-16l/min1"FLxM28 1.
18	8 735 300 759	Pumpe Para ST 15-130/7-50/iPWM2-6	Pump Para ST 15-130/7-50/iPWM2-6	Pompe Para ST 15-130/7-75/iPWM2-6	Circolatore Para ST 15-130/7-75/iPWM2-6	Bomba Para ST 15-130/7-75/iPWM2-6	Bomba Para ST 15-130/7-75/iPWM2-6
19	8 718 530 658 0	Durchflussbegrenzer	flow limiter	Limiteur de débit	Regolatore di flusso	limitador de caudal	limitador de fluxo
21	8 735 300 269	Kabel Pumpe 2,5m 230V everp	Cable pump 2,5m 230V	Câble pompe 2,5m 230V	Cavo Pompa 2,5m 230V	Cables bomba 2,5m 230V	Cabo bomba 2,5m 230V
22	8 735 300 270	Kabel 2,5m PWM	Cable 2,5m PWM	Câble 2,5m PWM	Cavo 2,5m PWM	Cables 2,5m PWM	Cabo 2,5m PWM

Ersatzteilliste
Spare parts list
Liste des pièces de rechange
Lista parti di ricambio
Lista de repuestos
Catálogo de peças de substituição

AGS10E-2 - 7735600054

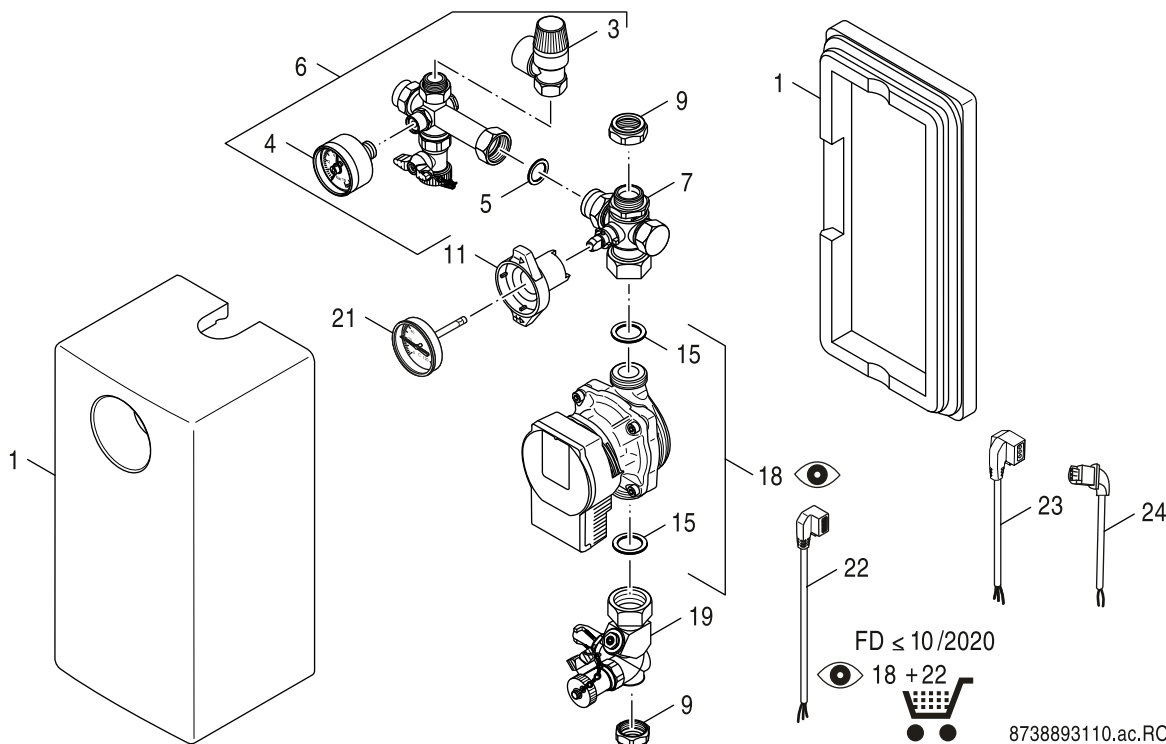

	Bestell-Nr.	Bezeichnung	Description	Dénomination	Descrizioni	Descripción	Designação
3	8 718 221 470 0	Sicherheitsventil 6 bar DN15	Safety relief valve 6 bar DN15	SOUPAPE DE SECURITE 6 BAR DN15	Valvola sicurezza 6 bar DN15	Válvula de sobrepresión 6 bar DN15	Válvula de segurança 6 bar DN15
4	8 735 300 266	Manometer 10 bar, 1/4"	Pressure gauge 10 bar, 1/4"	Manomètre 10 bar, 1/4"	Manometro 10 bar, 1/4"	Manómetro 10 bar, 1/4"	Manómetro
5	8 718 221 473 0	Dichtung 24 x 17 x 2 mm (2x)	Seal 24 x 17 x 2 mm (2x)	Joint 24 x 17 x 2 mm (2x)	Guarnizione 24 x 17 x 2 mm (2x)	Junta 24 x 17 x 2 mm (2x)	Vedante 24 x 17 x 2 mm (2x)
6	8 718 221 466 0	Sicherheitsgruppe	Safety group	Groupe de sécurité	Gruppo sicurezza	Grupo de seguridad	Conjunto de segurança
7	8 718 221 483 0	Kugelhahn	Ball valve	Robinet à boule	Valvola a sfera	Válvula	Válvula de esfera
9	8 718 221 452 0	Verschraubung 22mm (2x)	Connection union 22mm (2x)	RACC SONDE SANITAIRE 22MM (2x)	Raccordo 22mm (2x)	Racor 22mm (2x)	União roscada 22mm (2x)
9	8 735 300 339	Verschraubung 15mm (2x)	Screw fitting 15mm (2x)	Raccord sonde sanitaire 15mm (2x)	Connessioni giuntate 15mm (2x)	Unión roscada 15mm (2x)	União roscada 15mm (2x)
11	8 718 224 982 0	Griff blau 52mm	Handle blue 52mm	Manette bleu 52mm	Manopula blu 52mm	Llave de corte azul 52mm	Manípulo azul 52mm
15	8 735 300 261	Dichtung 30x21x2 (2x) everp	Gasket 30x21x2 (2x) sp	Joint 30x21x2 (2x)	Guarnizione 30x21x2 (2x)	Junta 30x21x2 (2x)	Vedação 30x21x2 (2x)
18	8 735 300 759	Pumpe Para ST 15-130/7-50/iPWM2-6	Pump Para ST 15-130/7-50/iPWM2-6	Pompe Para ST 15-130/7-75/iPWM2-6	Circolatore Para ST 15-130/7-75/iPWM2-6	Bomba Para ST 15-130/7-75/iPWM2-6	Bomba Para ST 15-130/7-75/iPWM2-6
19	8 718 221 456 0	Durchflussbegrenzer 2-16l/min1"FLxM28 1.	Flow limiter 2-16l/min1"FLxM28 1.5AG	Limiteur de débit 2-16l/min1"FLxM28 1.	Regolatore di flusso 2-16l/min1"FLxM28	Limitador de caudal 2-16l/min1"FLxM28 1.	Limitador de caudal 2-16l/min1"FLxM28 1
21	8 718 221 476 0	Thermometer	Thermometer	Thermomètre	Termometro	Termómetro	Termómetro
22	8 735 300 762	Kabel Pumpe 230V 2,5m PR60 everp	Cable pump 230V 2,5m PR60 packed	Câble pompe 230V 2,5m PR60	Cavo Pompa 230V 2,5m PR60	Cables bomba 230V 2,5m PR60	Cabo bomba 230V 2,5m PR60
23	8 735 300 269	Kabel Pumpe 2,5m 230V everp	Cable pump 2,5m 230V	Câble pompe 2,5m 230V	Cavo Pompa 2,5m 230V	Cables bomba 2,5m 230V	Cabo bomba 2,5m 230V
24	8 735 300 270	Kabel 2,5m PWM	Cable 2,5m PWM	Câble 2,5m PWM	Cavo 2,5m PWM	Cables 2,5m PWM	Cabo 2,5m PWM

Ersatzteilliste
Spare parts list
Liste des pièces de rechange
Lista parti di ricambio
Lista de repuestos
Catálogo de peças de substituição

AGS20-2 - 7735600060

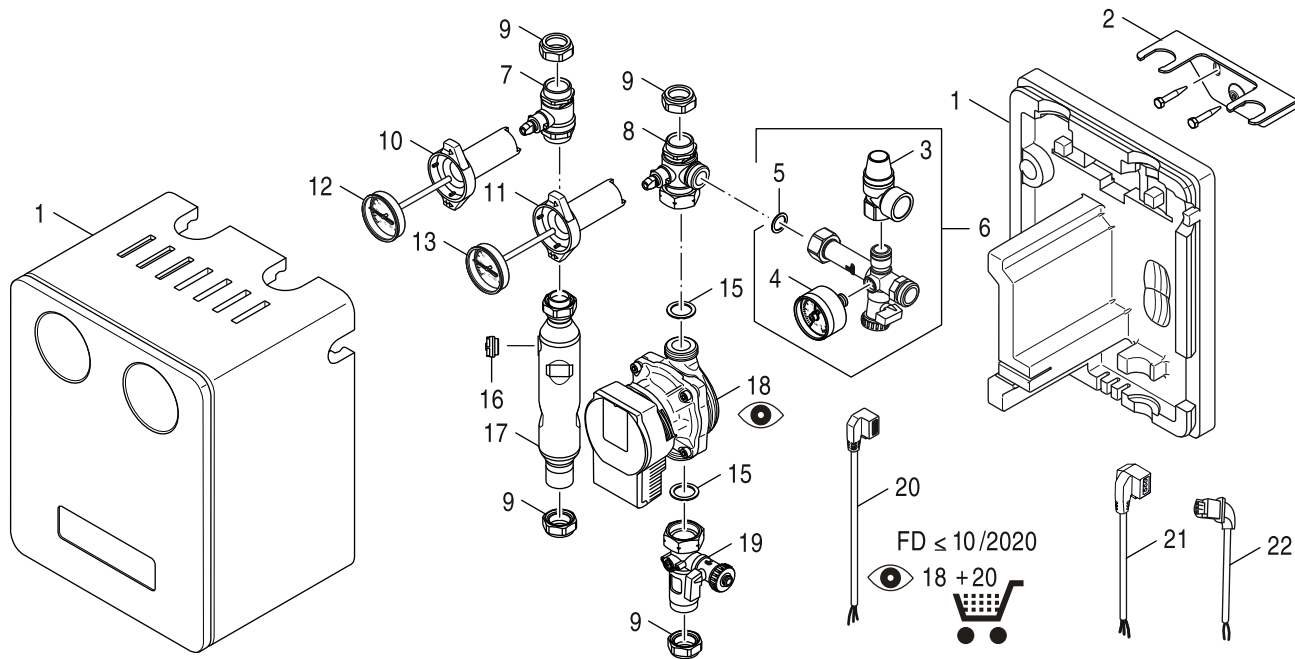

8738893050.ac.RO

	Bestell-Nr.	Bezeichnung	Description	Dénomination	Descrizioni	Descripción	Designação
1	8 735 300 263	Isolierung	Insulation	Isolation	Coibentazione	Aislamiento	Isolamento
2	8 735 300 267	Halter (10 & 20)	Holder (10 & 20)	Support (10 & 20)	Supporto (10 & 20)	Soporte (10 & 20)	Suporte (10 & 20)
3	8 718 221 470 0	Sicherheitsventil 6 bar DN15	Safety relief valve 6 bar DN15	SOUPAPE DE SECURITE 6 BAR DN15	Valvola sicurezza 6 bar DN15	Válvula de sobrepresión 6 bar DN15	Válvula de segurança 6 bar DN15
4	8 735 300 266	Manometer 10 bar, 1/4"	Pressure gauge 10 bar, 1/4"	Manomètre 10 bar, 1/4"	Manometro 10 bar, 1/4"	Manómetro 10 bar, 1/4"	Manómetro
5	8 718 221 473 0	Dichtung 24 x 17 x 2 mm (2x)	Seal 24 x 17 x 2 mm (2x)	Joint 24 x 17 x 2 mm (2x)	Guarnizione 24 x 17 x 2 mm (2x)	Junta 24 x 17 x 2 mm (2x)	Vedante 24 x 17 x 2 mm (2x)
6	8 735 300 259	Sicherheitsgruppe (10 & 20)	Safety assembly (10 & 20)	Groupe de sécurité (10 & 20)	Gruppo sicurezze (10 & 20)	Grupo de seguridad (10 & 20)	Módulo de segurança (10 & 20)
7	7 735 600 309	Kugelhahn	Ball valve	Robinet à boule	Valvola a sfera	Válvula	Válvula de esfera
8	7 735 600 310	Kugelhahn	Ball valve	Robinet à boule	Valvola a sfera	Válvula	Válvula de esfera
9	7 735 600 313	Verschraubung 22mm (2x)	Connection union 22mm (2x)	RACC SONDE SANITAIRE 22MM (2x)	Raccordo 22mm (2x)	Racor 22mm (2x)	União roscada 22mm (2x)
10	7 735 600 314	Griff rot 92mm	Handle red 92mm	Manette rouge 92mm	Manopola rosso 92mm	Mando del grifo rojo 92mm	Manipulo vermelho 92mm
11	7 735 600 315	Griff blau 92mm	Handle blue 92mm	Manette bleue 92mm	Manopola blu 92mm	Llave de corte azul 92mm	Manete do termometro azul 92mm
12	8 735 300 264	Thermometer (10 & 20) rot	Thermometer (10 & 20) red	Thermomètre (10 & 20) rouge	Termometro (10 & 20) rosso	Termómetro (10 & 20) rojo	Termómetro (10 & 20) vermelho
13	8 735 300 265	Thermometer (10 & 20) blau	Thermometer (10 & 20) blue	Thermomètre (10 & 20) bleu	Termometro (10 & 20) blu	Termómetro (10 & 20) azul	Termómetro (10 & 20) azul
15	8 735 300 261	Dichtung 30x21x2 (2x) everp	Gasket 30x21x2 (2x) sp	Joint 30x21x2 (2x)	Guarnizione 30x21x2 (2x)	Junta 30x21x2 (2x)	Vedação 30x21x2 (2x)
16	8 718 221 485 0	Stopfen 3/8" 150°C	Grommet 3/8" 150°C	Bouchon 3/8" 150°C	Coperchietto 3/8" 150°C	Tapon 3/8" 150°C	Bujão 3/8" 150°C
17	8 718 224 984 0	Luftabscheider	air separator	séparateur air 2-16l/min1"FLxM28 1	Separatore aria con 2-16l/min1"FLxM28 1	separador de aire	separador de ar 2-16l/min1"FLxM28 1.
18	8 735 300 760	Pumpe Para ST 15-130/8-75/iPWM2-6	Pump Para ST 15-130/8-75/iPWM2-6	Pompe Para ST 15-130/8-75/iPWM2-6	Circolatore Para ST 15-130/8-75/iPWM2-6	Bomba para ST 15-130/8-75/iPWM2-6	Bomba Para ST 15-130/8-75/iPWM2-6
19	8 735 300 272	Durchflussbegrenzer 8-20 l/min	Flow limiter 8-20 l/min	Limiteur de débit 8-20 l/min	Regolatore di flusso 8-20 l/min	Limitador de caudal 8-20 l/min	Limitador de fluxo 8-20 l/min
20	8 735 300 762	Kabel Pumpe 230V 2,5m PR60 everp	Cable pump 230V 2,5m PR60 packed	Câble pompe 230V 2,5m PR60	Cavo Pompa 230V 2,5m PR60	Cables bomba 230V 2,5m PR60	Cabo bomba 230V 2,5m PR60
21	8 735 300 269	Kabel Pumpe 2,5m 230V everp	Cable pump 2,5m 230V	Câble pompe 2,5m 230V	Cavo Pompa 2,5m 230V	Cables bomba 2,5m 230V	Cabo bomba 2,5m 230V
22	8 735 300 270	Kabel 2,5m PWM	Cable 2,5m PWM	Câble 2,5m PWM	Cavo 2,5m PWM	Cables 2,5m PWM	Cabo 2,5m PWM

Ersatzteilliste
Spare parts list
Liste des pièces de rechange
Lista parti di ricambio
Lista de repuestos
Catálogo de peças de substituição

AGS50-2 - 7735600061

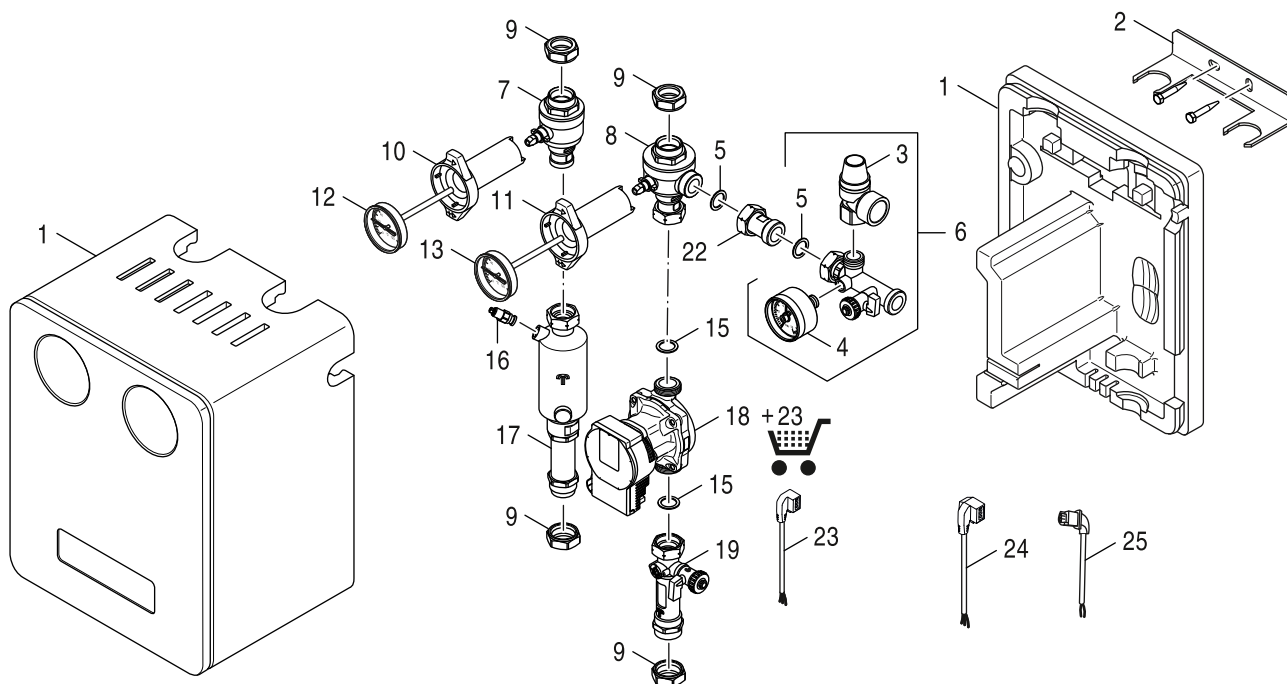

8738893049.ac.RO

	Bestell-Nr.	Bezeichnung	Description	Dénomination	Descrizioni	Descripción	Designação
1	8 735 300 263	Isolierung	Insulation	Isolation	Coibentazione	Aislamiento	Isolamento
2	8 735 300 284	Halter (50)	Insulation mineral wool SKW	Support (50)	Supporto (50)	Soporte (50)	Suporte (50)
3	8 735 300 274	Sicherheitsventil (50)	Safety valve (50)	Soupape de sécurité (50)	Valvola di sicurezza (50)	Válvula de seguridad (50)	Válvula de segurança (50)
4	8 735 300 266	Manometer 10 bar, 1/4"	Pressure gauge 10 bar, 1/4"	Manomètre 10 bar, 1/4"	Manometro 10 bar, 1/4"	Manómetro 10 bar, 1/4"	Manómetro
5	8 735 300 261	Dichtung 30x21x2 (2x) everp	Gasket 30x21x2 (2x) sp	Joint 30x21x2 (2x)	Guarnizione 30x21x2 (2x)	Junta 30x21x2 (2x)	Vedação 30x21x2 (2x)
6	8 735 300 273	Sicherheitsgruppe (50)	Safety assembly (50)	Groupe de sécurité (50)	Gruppo sicurezze (50)	Grupo de seguridad (50)	Válvula de segurança (50)
7	8 735 300 278	Kugelhahn VL	Ball valve VL	Robinet à boisseau sphérique VL	Rubinetto a sfera VL	Válvula de bola VL	Válvula de esfera VL
8	8 735 300 279	Kugelhahn RL	Ball valve RL	Robinet à boisseau sphérique RL	Rubinetto a sfera RL	Válvula de bola RL	Válvula de esfera RL
9	8 735 300 276	Verschraubung 28 mm	Connection union 28mm (2x)	Raccord sonde sanitaire 28mm (2x)	Raccordo 28mm (2x)	Tuerca compresión 28mm (2x)	União roscada 28mm (2x)
10	8 735 300 283	Griff (50) rot	Handle (50) red	Poignée (50) rouge	Manopola (50) rosso	Mando del grifo (50) rojo	Manípulo (50) vermelho
11	8 735 300 285	Griff (50) blau	Handle (50) blue	Poignée (50) bleu	Manopola (50) blu	Mando del grifo (50) azul	Manípulo (50) azul
12	8 735 300 298	Thermometer (50) rot	thermometer (50) red	thermomètre (50) rouge	Termometro (50) rosso	termómetro (50) rojo	Termómetro (50) vermelho
13	8 735 300 299	Thermometer (50) blau	thermometer (50) blue	thermomètre (50) bleu	Termometro (50) blu	termómetro (50) azul	Termómetro (50) azul
15	8 735 300 261	Dichtung 30x21x2 (2x) everp	Gasket 30x21x2 (2x) sp	Joint 30x21x2 (2x)	Guarnizione 30x21x2 (2x)	Junta 30x21x2 (2x)	Vedação 30x21x2 (2x)
16	8 735 300 277	Stopfen (50)	Plug (50)	Bouchon (50)	Tappo (50)	Tapon (50)	Tampão (50)
17	8 735 300 280	Luftabscheider DN 25	Air separator DN 25	Séparateur air DN 25	Separatore aria con sfiato DN 25	Separador de aire DN 25	Separador de ar DN 25
18	8 735 300 774	Pumpe Para 15-130/9-87/iPWM2-6	Pump Para 15-130/9-87/iPWM2-6	Pompe Para 15-130/9-87/iPWM2-6	Circolatore Para 15-130/9-87/iPWM2-6	Bomba Para 15-130/9-87/iPWM2-6	Bomba Para 15-130/9-87/iPWM2-6
19	8 735 300 286	Durchflussbegrenzer 5-45 l/min	Flow limiter 5-45 l/min	Limiteur de débit 5-45 l/min	Regolatore di flusso 5-45 l/min	Limitador de caudal 5-45 l/min	Limitador de fluxo 5-45 l/min
22	8 735 300 302	Verschraubung DN25	Screw fitting DN25	raccord sonde sanitaire DN 25	serraggio a vite DN 25	unión roscada DN 25	União roscada DN 25
23	8 735 300 762	Kabel Pumpe 230V 2,5m PR60 everp	Cable pump 230V 2,5m PR60 packed	Câble pompe 230V 2,5m PR60	Cavo Pompa 230V 2,5m PR60	Cables bomba 230V 2,5m PR60	Cabo bomba 230V 2,5m PR60
24	8 735 300 269	Kabel Pumpe 2,5m 230V everp	Cable pump 2,5m 230V	Câble pompe 2,5m 230V	Cavo Pompa 2,5m 230V	Cables bomba 2,5m 230V	Cabo bomba 2,5m 230V
25	8 735 300 270	Kabel 2,5m PWM	Cable 2,5m PWM	Câble 2,5m PWM	Cavo 2,5m PWM	Cables 2,5m PWM	Cabo 2,5m PWM

Ersatzteilliste
 Spare parts list
 Liste des pièces de rechange
 Lista parti di ricambio
 Lista de repuestos
 Catálogo de peças de substituição

TDS100-2 - 7735600067

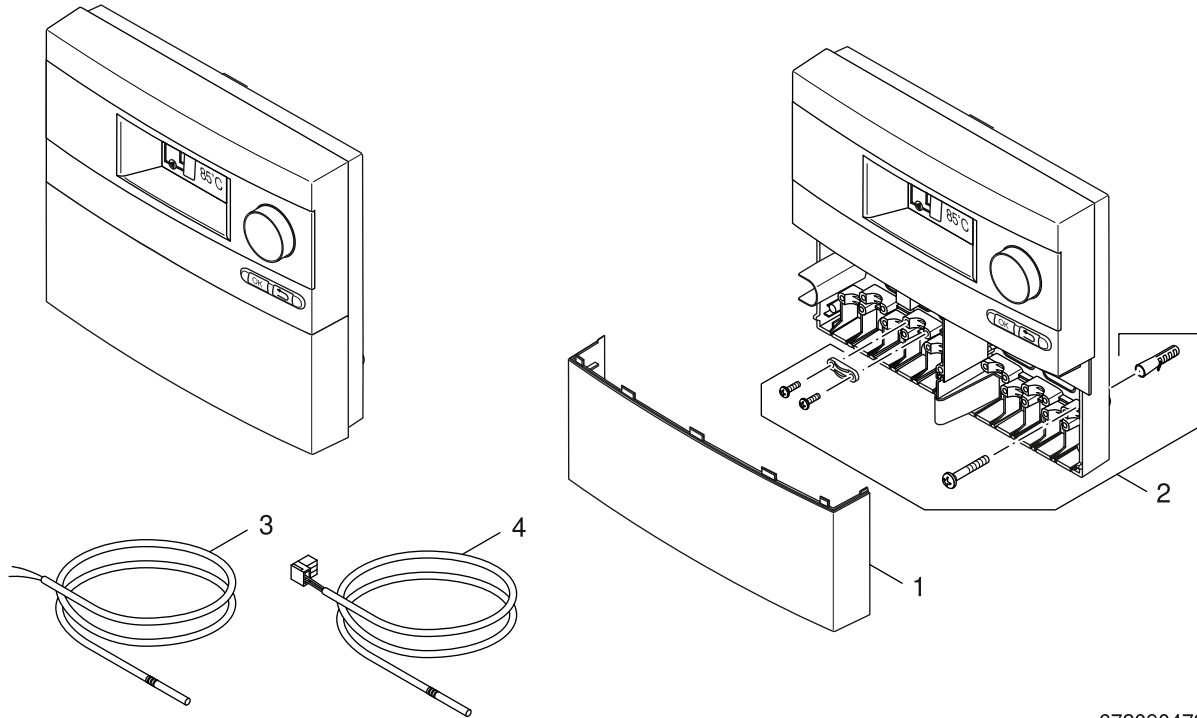

6720904797.AA.RS

	Bestell-Nr.	Bezeichnung	Description	Dénomination	Descrizioni	Descripción	Designação
1	8 718 220 947 0	Deckel 190x75x30	cover 190x75x30	COUVERCLE POUR SC20	Coperchio 190x75x30	Recubrimiento 190x75x30	Tampa 190x75x30
2	8 718 220 949 0	Befestigungsset Classic/Top	Fixing set	SACHET DE FIXATION	Set di fissaggio Classic / Top	Juego de tornillos. SC20/40	Conjunto de fixação
3	8 747 208 172 0	Kollektorfühler 35x6 2500mm 20k	Solar collector sensor 35x6 2500mm 20k	Sonde capteur solaire 35x6 2500mm 20k	Sonda collectore solare 35x6 2500mm 20k	Sonda colector solar 35x6 2500mm 20k	Sonda de temperatura
4	7 735 502 304	Temperaturfühler NTC RD 6,0 12K 6000mm	Temperature sensor NTC RD 6,0 12K 6000mm	Kit capteurs NTC RD 6,0 12K 6000 emballé	Sonda di temperatura NTC RD 6,0 12K 6000	Sensor temperatura NTC RD 6,0 12K 6000mm	Sensor temperatura NTC RD 6,0 12K 6000mm

Ersatzteilliste
 Spare parts list
 Liste des pièces de rechange
 Lista parti di ricambio
 Lista de repuestos
 Catálogo de peças de substituição

TDS100-2 - 7735600068

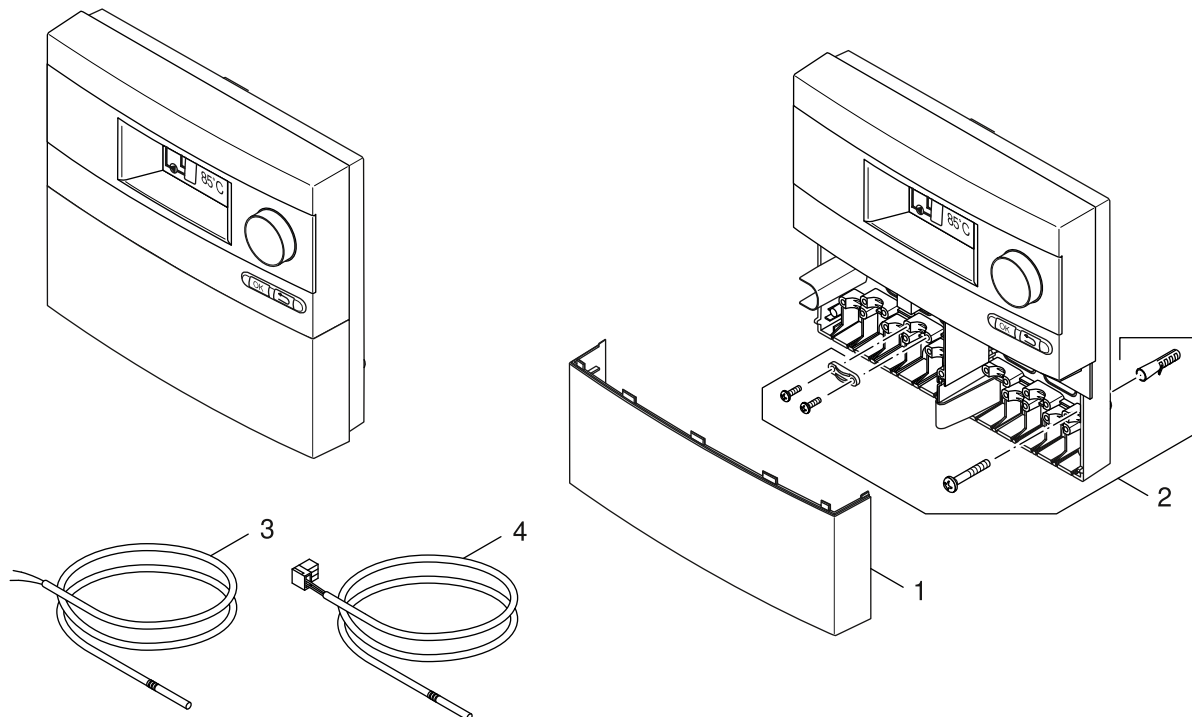

6720904797.AA.RS

	Bestell-Nr.	Bezeichnung	Description	Dénomination	Descrizioni	Descripción	Designação
1	8 718 220 947 0	Deckel 190x75x30	cover 190x75x30	COUVERCLE POUR SC20	Coperchio 190x75x30	Recubrimiento 190x75x30	Tampa 190x75x30
2	8 718 220 949 0	Befestigungsset Classic/Top	Fixing set	SACHET DE FIXATION	Set di fissaggio Classic / Top	Juego de tornillos. SC20/40	Conjunto de fixação
3	8 747 208 172 0	Kollektorfühler 35x6 2500mm 20k	Solar collector sensor 35x6 2500mm 20k	Sonde capteur solaire 35x6 2500mm 20k	Sonda collectore solare 35x6 2500mm 20k	Sonda colector solar 35x6 2500mm 20k	Sonda de temperatura
4	7 735 502 304	Temperaturfühler NTC RD 6,0 12K 6000mm	Temperature sensor NTC RD 6,0 12K 6000mm	Kit capteurs NTC RD 6,0 12K 6000 emballé	Sonda di temperatura NTC RD 6,0 12K 6000	Sensor temperatura NTC RD 6,0 12K 6000mm	Sensor temperatura NTC RD 6,0 12K 6000mm

Ersatzteilliste
Spare parts list
Liste des pièces de rechange
Lista parti di ricambio
Lista de repuestos
Catálogo de peças de substituição

WMZ 10-2 - 7735600127

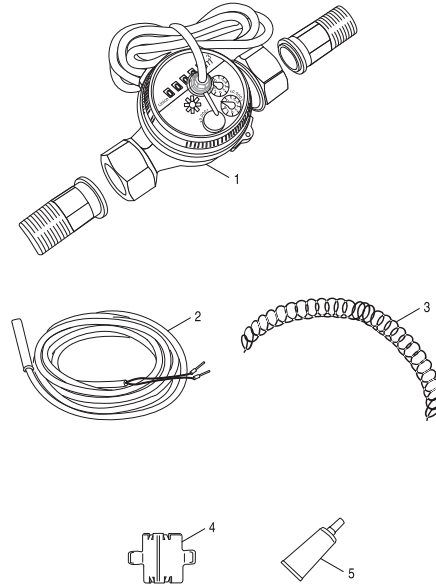

8738893290,as,RO

	Bestell-Nr.	Bezeichnung	Description	Dénomination	Descrizioni	Descripción	Designação
1	6 301 353 4	Volumenmessteil V40 1,0m3/h DN20 everp	Volume measuring element V40 1,0m3/h	Mesureur de volume V40 1,0m3/h DN20 Sig	Misuratore Di Flusso V40 1,0m3/h DN20	Medidor De Corriente V40 1,0m3/h DN20	Medidor de Vazão V40 1,0m3/h DN20
2	7 735 502 304	Temperaturfühler NTC RD 6,0 12K 6000mm	Temperature sensor NTC RD 6,0 12K 6000mm	Kit capteurs NTC RD 6,0 12K 6000 emballé	Sonda di temperatura NTC RD 6,0 12K 6000	Sensor temperatura NTC RD 6,0 12K 6000mm	Sensor temperatura NTC RD 6,0 12K 6000mm
3	8 718 570 710 0	Spannfeder für Anlegefühler everp	Tensioning spring temperature sensor	RESSORT DE TENSION PR SONDE DE TEMP	Molla di tensione Sensore sicurezza tem.	Muelle tensor sensor de temperatura	Mola de aperto sensor da temperatura
4	8 718 570 709 0	Halteblech für Anlegefühler everp	Holding plate temperature sensor	SONDE TEMP. POUR PLAQUE JONCTION	Lamierino Sensore sicurezza di temperat.	Placa de unión sonda temperatura	Chapa de retenção sensor da temperatura
5	8 719 918 658 0	Wärmeleitpaste 20 ML everp	Heat conducting paste 20 ML	Pate Thermocond. 20 ML.	Pasta termoconduttrice 20 ML	Pasta termoconductor 20 ML	Massa termoconductor 20 ML

Ersatzteilliste
Spare parts list
Liste des pièces de rechange
Lista parti di ricambio
Lista de repuestos
Catálogo de peças de substituição

WMZ 15-2 - 7735600128

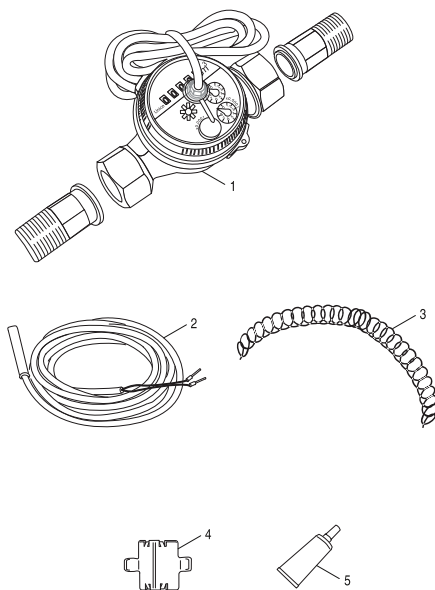

8738893290,aa,RO

	Bestell-Nr.	Bezeichnung	Description	Dénomination	Descrizioni	Descripción	Designação
1	8 510 323 8	Volumenmessteil V40 1,5 m ³ /h DN20	Volume measuring element V40 1.5 m ³ /h	Mesureur de volume V40 1,5m ³ /h DN20	Misuratore Di Flusso V40 1,5m ³ /h DN20	Medidor De Corriente V40 1,5m ³ /h DN20	Medidor de Vazão V40 1,5m ³ /h DN20
2	7 735 502 304	Temperaturfühler NTC RD 6,0 12K 6000mm	Temperature sensor NTC RD 6,0 12K 6000mm	Kit capteurs NTC RD 6,0 12K 6000 emballé	Sonda di temperatura NTC RD 6,0 12K 6000	Sensor temperatura NTC RD 6,0 12K 6000mm	Sensor temperatura NTC RD 6,0 12K 6000mm
3	8 718 570 710 0	Spannfeder für Anlegefühler everp	Tensioning spring temperature sensor	RESSORT DE TENSION PR SONDE DE TEMP	Molla di tensione Sensore sicurezza tem.	Muelle tensor sensor de temperatura	Mola de aperto sensor da temperatura
4	8 718 570 709 0	Halteblech für Anlegefühler everp	Holding plate temperature sensor	SONDE TEMP. POUR PLAQUE JONCTION	Lamierino Sensore sicurezza di temperat.	Placa de unión sonda temperatura	Chapa de retenção sensor da temperatura
5	8 719 918 658 0	Wärmeleitpaste 20 ML everp	Heat conducting paste 20 ML	Pate Thermocond. 20 ML.	Pasta termoconduttrice 20 ML	Pasta termoconductor 20 ML	Massa termoconductor 20 ML

Ersatzteilliste
Spare parts list
Liste des pièces de rechange
Lista parti di ricambio
Lista de repuestos
Catálogo de peças de substituição

WMZ 5-2 - 7735600126

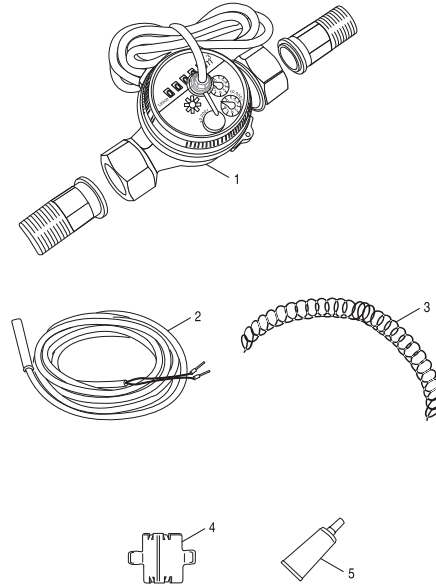

8738893290,aa,RO

	Bestell-Nr.	Bezeichnung	Description	Dénomination	Descrizioni	Descripción	Designação
1	8 510 323 8	Volumenmessteil V40 1,5 m ³ /h DN20	Volume measuring element V40 1.5 m ³ /h	Mesureur de volume V40 1,5m ³ /h DN20	Misuratore Di Flusso V40 1,5m ³ /h DN20	Medidor De Corriente V40 1,5m ³ /h DN20	Medidor de Vazão V40 1,5m ³ /h DN20
2	7 735 502 304	Temperaturfühler NTC RD 6,0 12K 6000mm	Temperature sensor NTC RD 6,0 12K 6000mm	Kit capteurs NTC RD 6,0 12K 6000 emballé	Sonda di temperatura NTC RD 6,0 12K 6000	Sensor temperatura NTC RD 6,0 12K 6000mm	Sensor temperatura NTC RD 6,0 12K 6000mm
3	8 718 570 710 0	Spannfeder für Anlegefühler everp	Tensioning spring temperature sensor	RESSORT DE TENSION PR SONDE DE TEMP	Molla di tensione Sensore sicurezza tem.	Muelle tensor sensor de temperatura	Mola de aperto sensor da temperatura
4	8 718 570 709 0	Halteblech für Anlegefühler everp	Holding plate temperature sensor	SONDE TEMP. POUR PLAQUE JONCTION	Lamierino Sensore sicurezza di temperat.	Placa de unión sonda temperatura	Chapa de retenção sensor da temperatura
5	8 719 918 658 0	Wärmeleitpaste 20 ML everp	Heat conducting paste 20 ML	Pate Thermocond. 20 ML.	Pasta termoconduttrice 20 ML	Pasta termoconductor 20 ML	Massa termoconductor 20 ML



Bosch Thermotechnik GmbH
Junkersstr. 20-24
D-73249 Wernau / Germany