

PROGRAMMA MISCELAZIONE BAGNO  
BATH MIXING PROGRAM  
PROGRAMME DU MITIGEUR POUR LA SALLE DE BAIN  
BAD-MISCHUNGSPROGRAMM  
PROGRAMA MEZCLADORES BAÑO  
ПРОГРАММА СМЕСИТЕЛЕЙ ДЛЯ ВАННОЙ  
ΛΟΥΤΡΟ ΠΟΥ ΑΝΑΜΙΓΝΥΕΙ ΤΟ ΠΡΟΓΡΑΜΜΑ  
浴室混水产品

Art. 41504-41506-41508-41510

Art. 43004-43006-43008-43010

Art. 43024-43026-43028-43030

Art. 43044-43046-43048-43050

Art. 43064-43066-43068-43070

Art. 43084-43086-43088-43090

Art. 45204-45206-45208-45210

Art. 46204-46206-46208-46210

Art. 58204-58206-58208-58210

Art. 58224-58226-58228-58230

Art. 65200-65204-65208

Art. 75314-75316-75318-75320

**GI**SSI THE  
PRIVATE  
WELLNESS  
COMPANY®



GISSI SpA  
Parco Gessi - 13037 Serravalle Sesia  
(Vercelli) ITALY  
Tel. +39 0163 454111  
Fax +39 0163 459273  
[www.gessi.com](http://www.gessi.com) - [gessi@gessi.it](mailto:gessi@gessi.it)



### ART. 41504

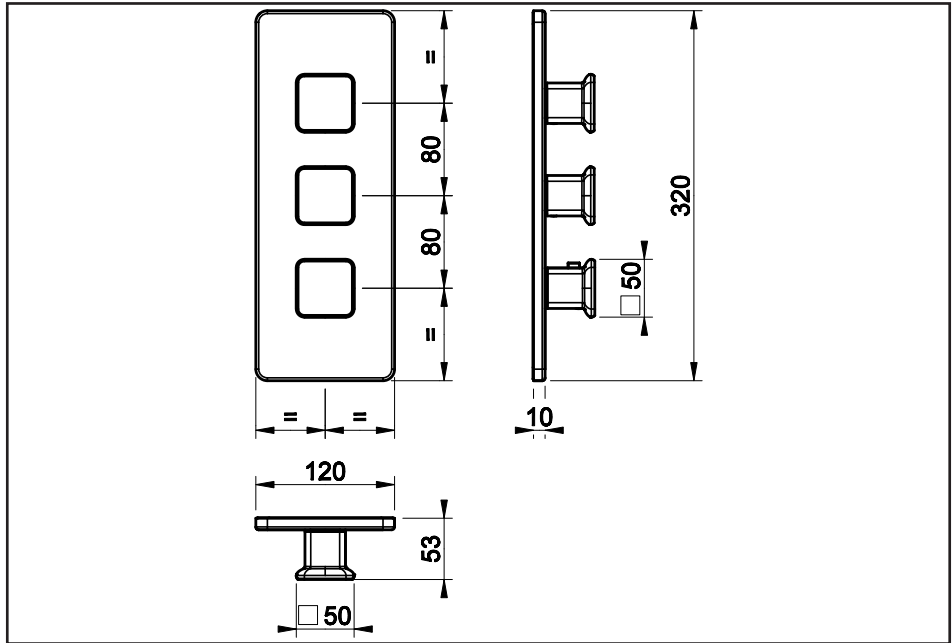

### ART. 41506

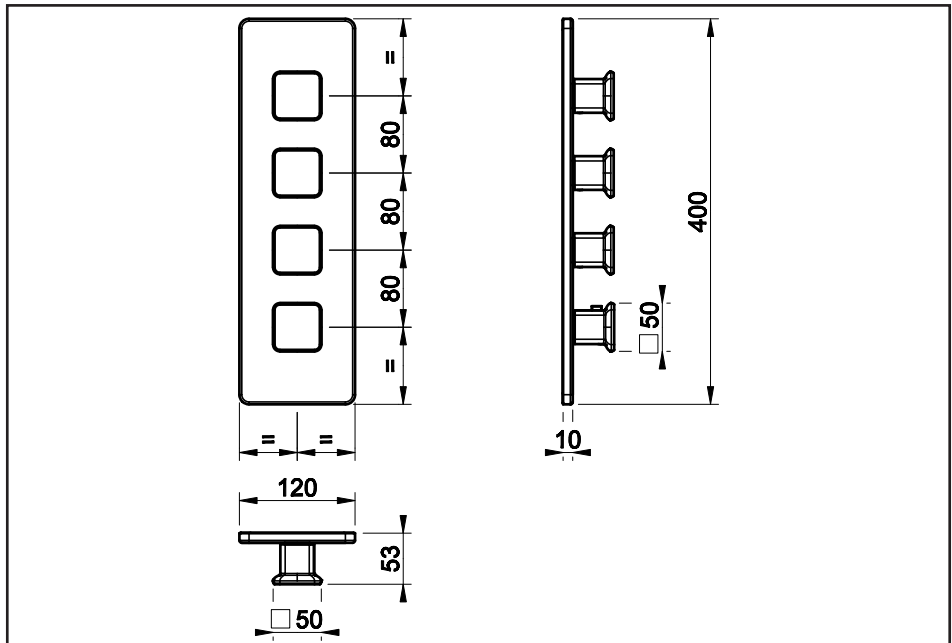



### ART. 41508

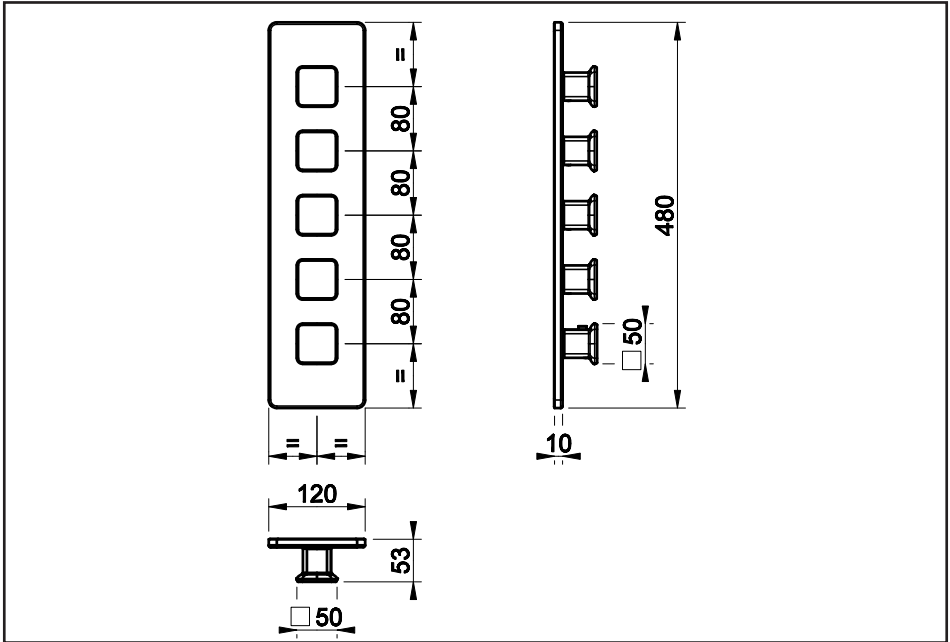

### ART. 41510

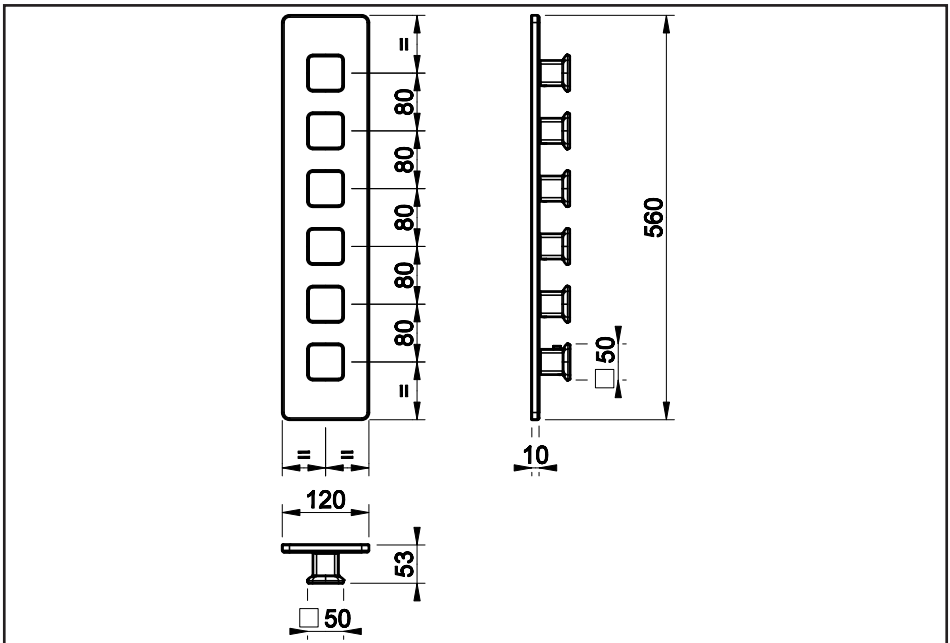



### ART. 43004

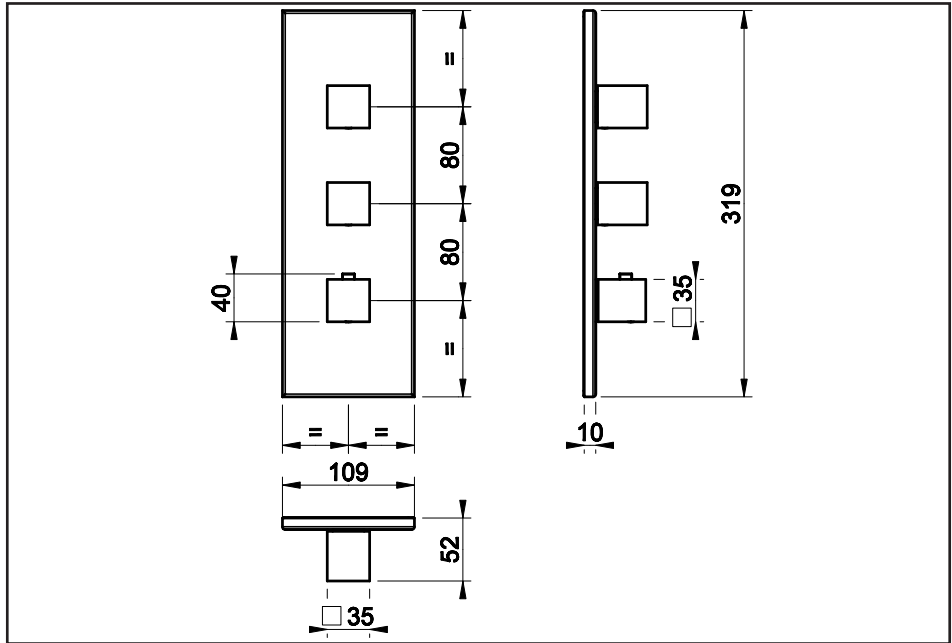

### ART. 43006

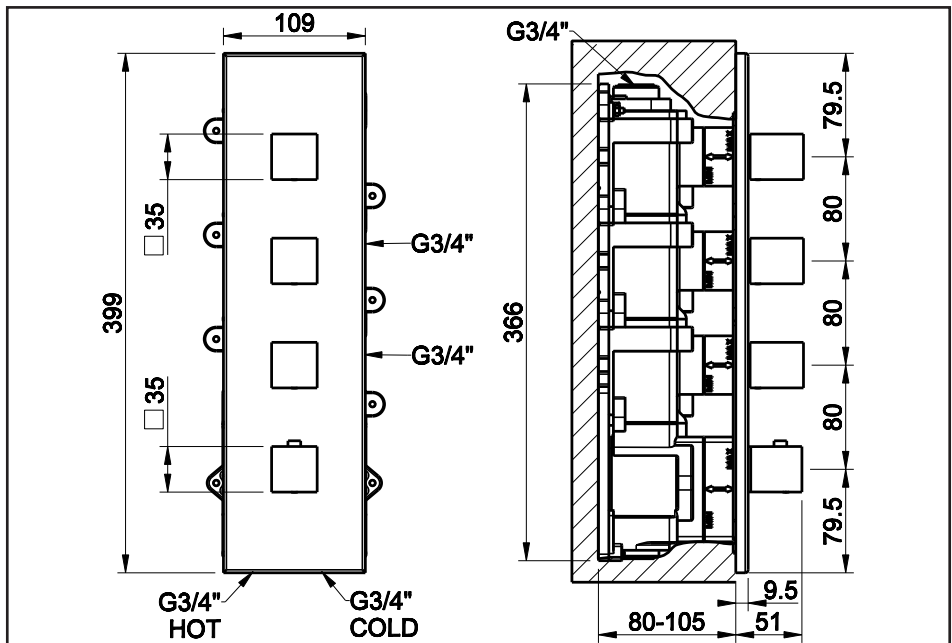



### ART. 43008

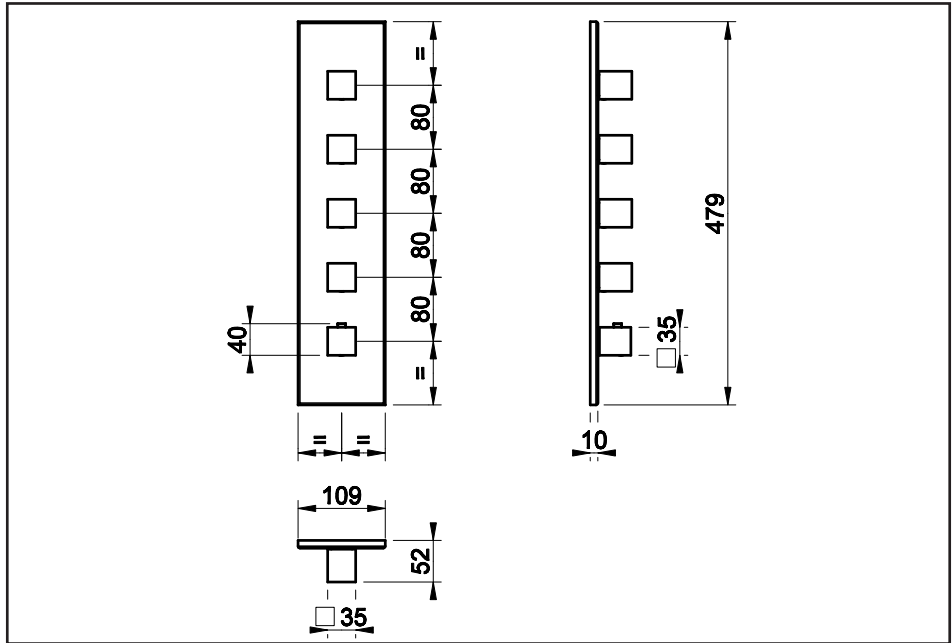

### ART. 43010

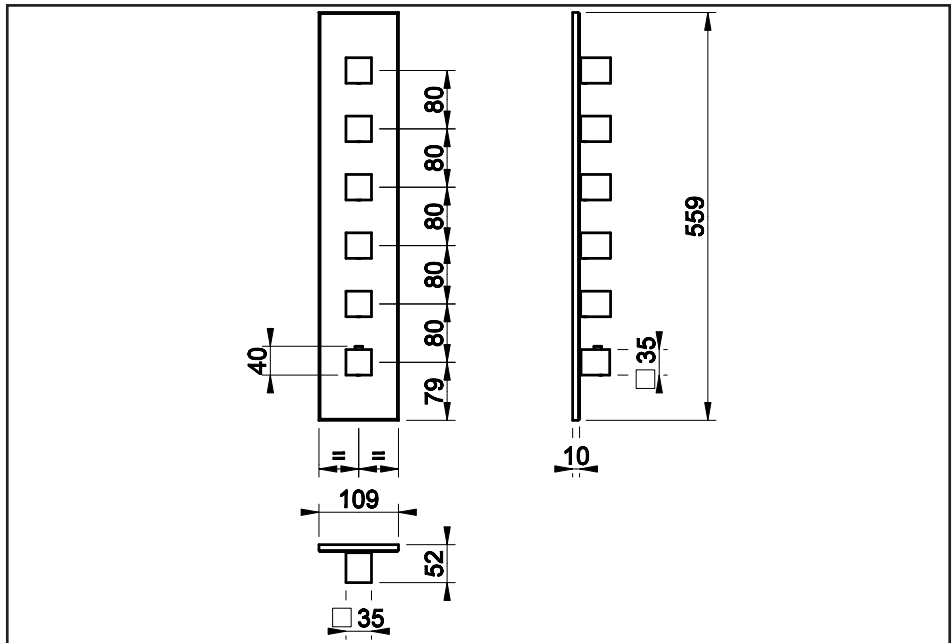



### ART. 43024

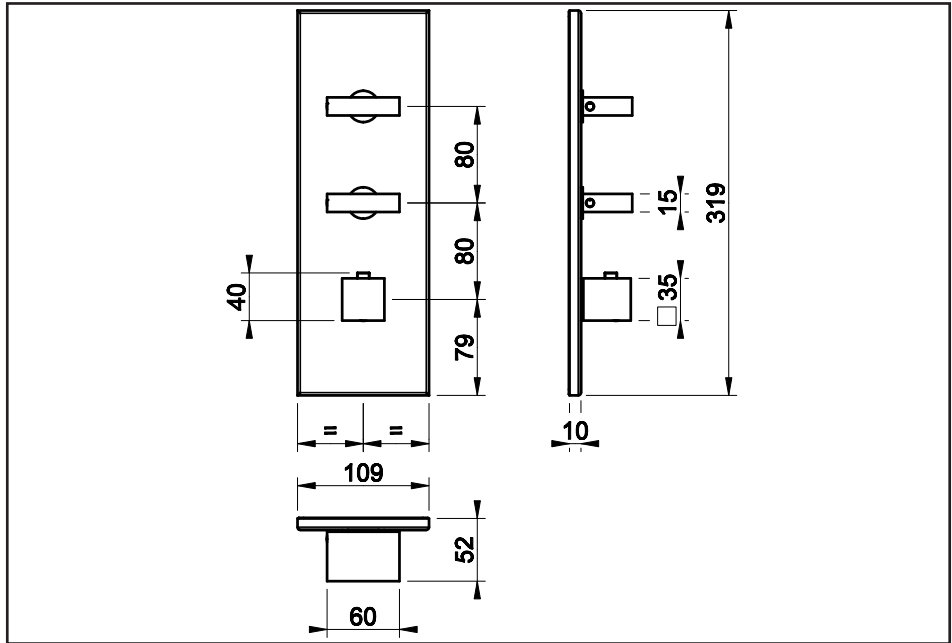

### ART. 43026

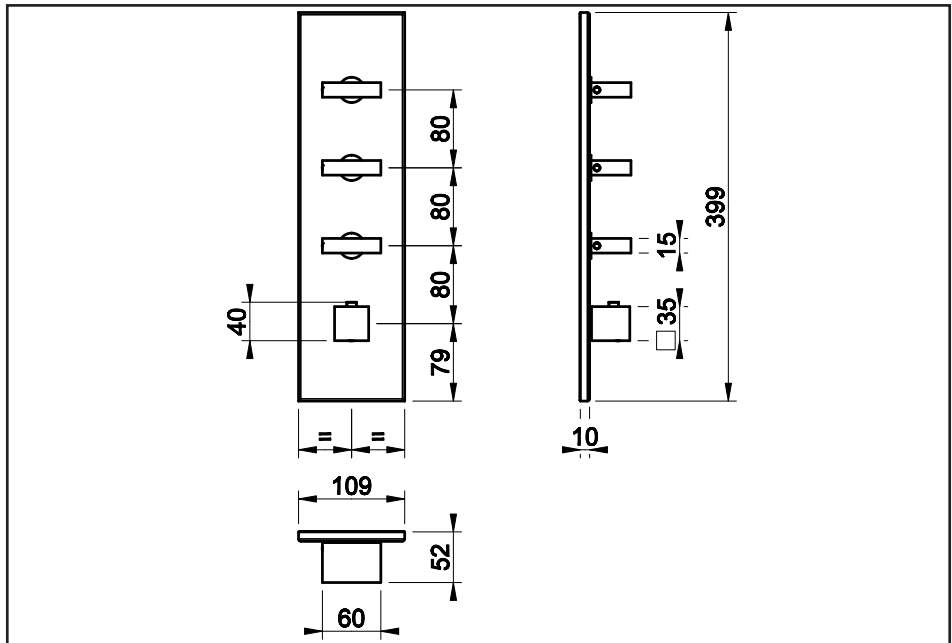



### ART. 43028

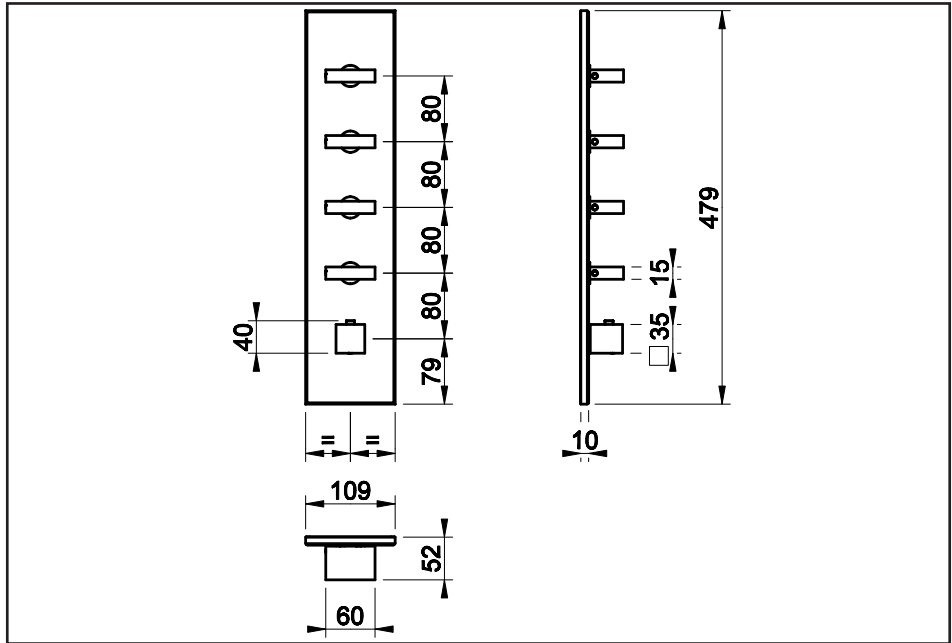

### ART. 43030

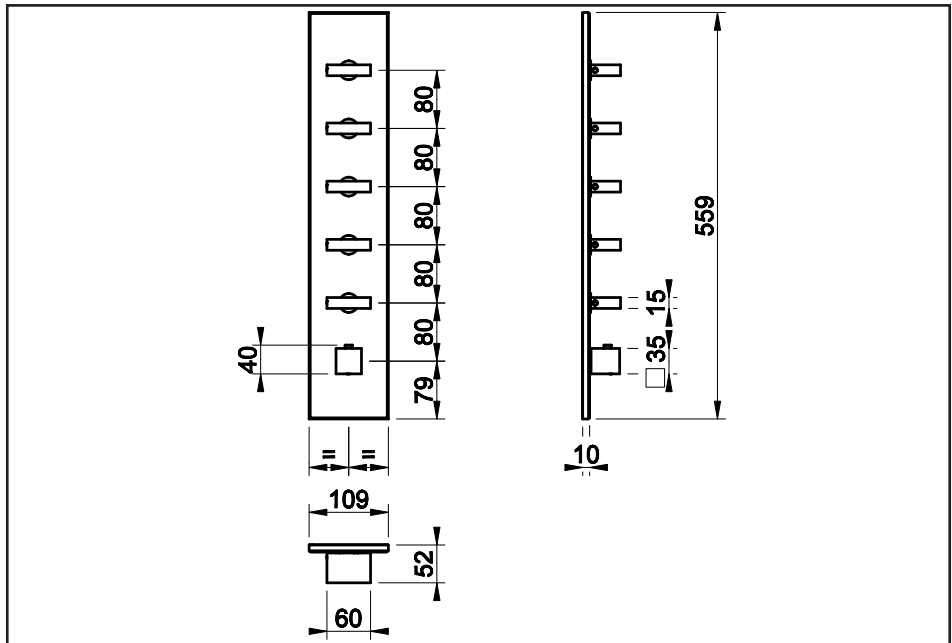



### ART. 43044

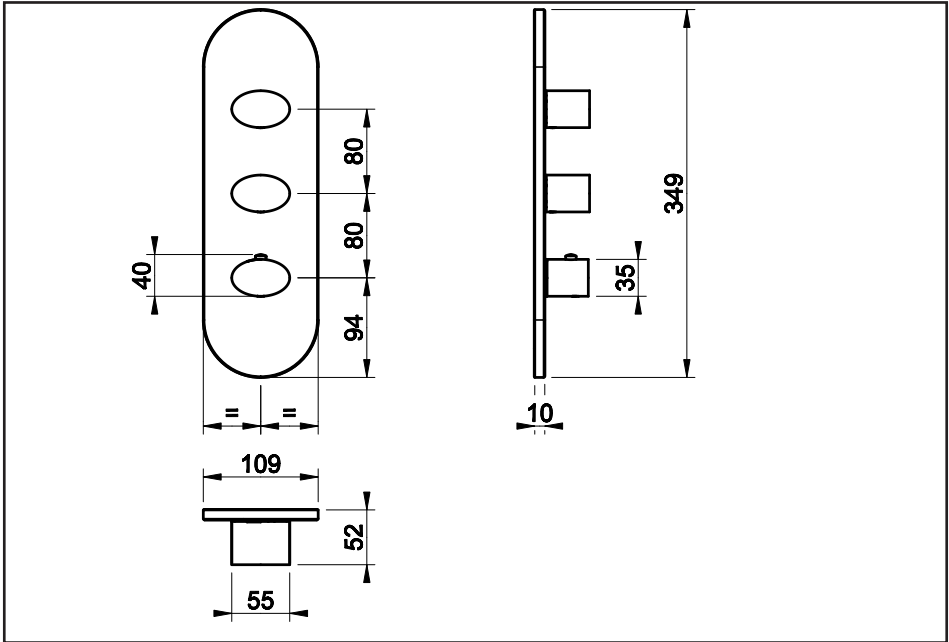

### ART. 43046

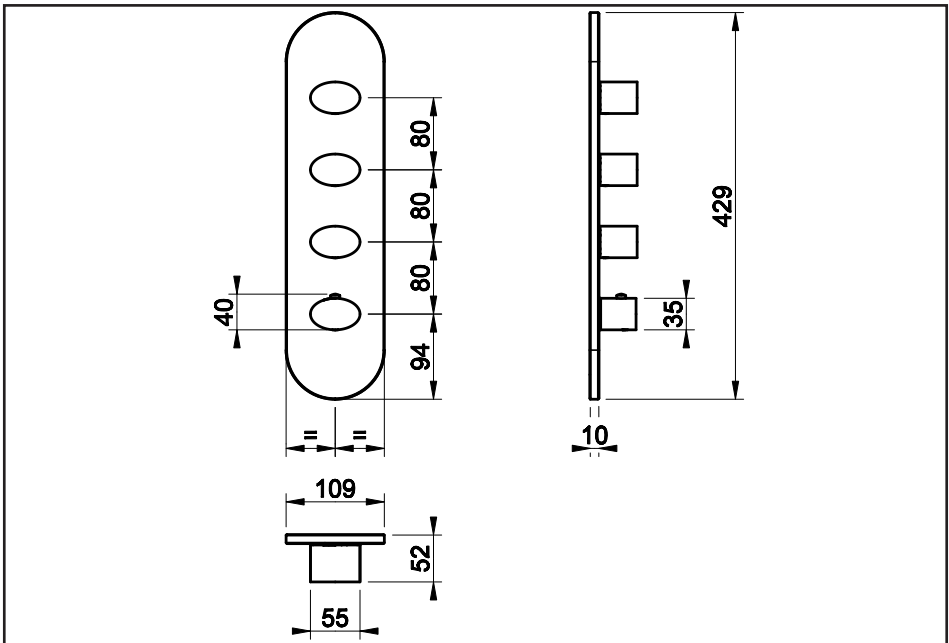



### ART. 43048

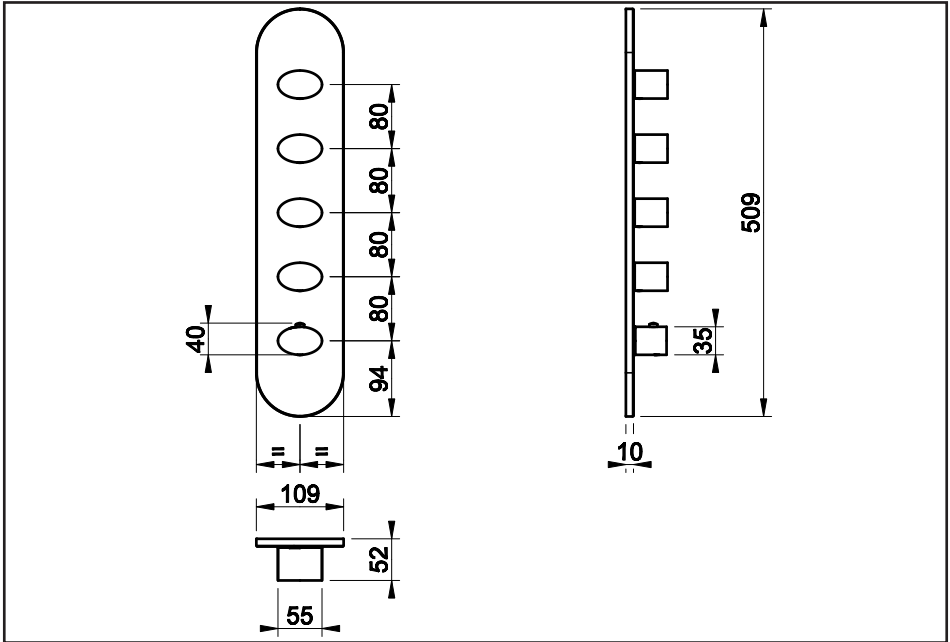

### ART. 43050

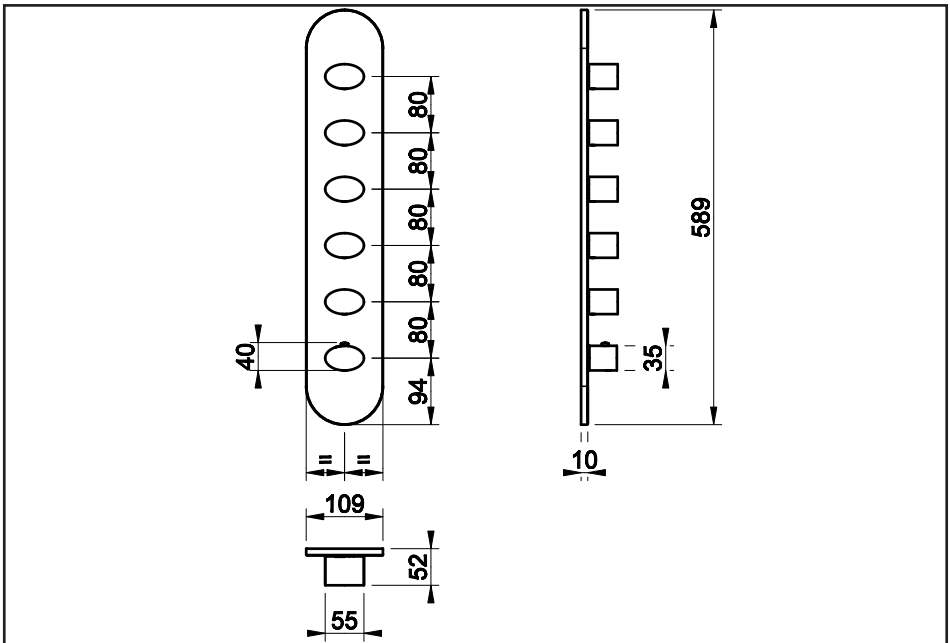



### ART. 43064

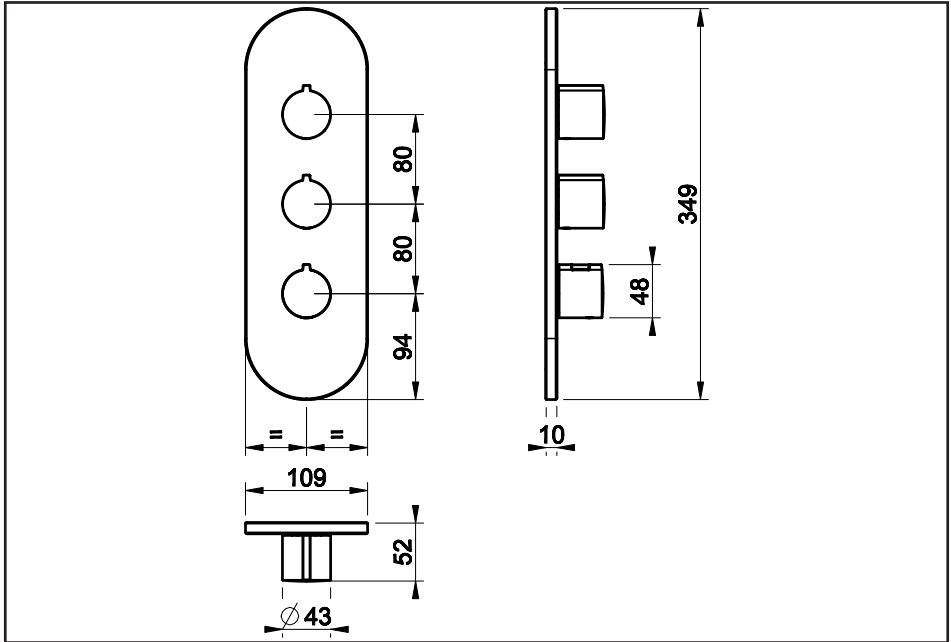

### ART. 43066

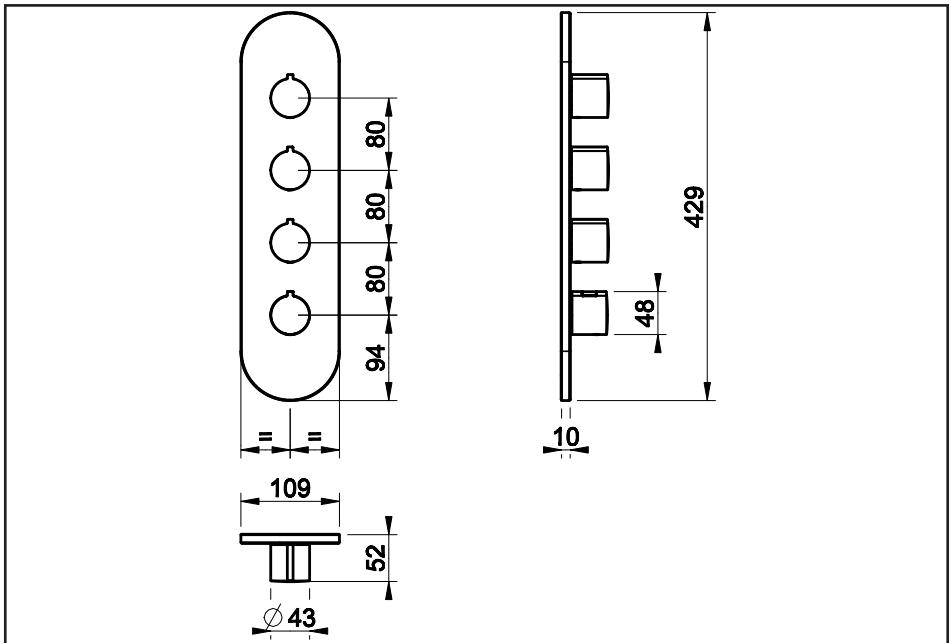



### ART. 43068

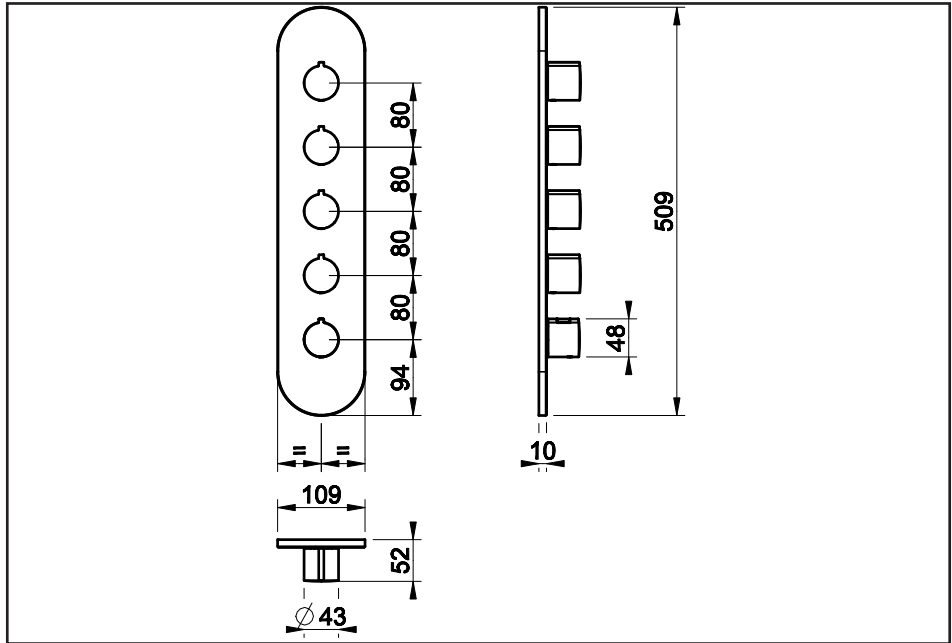

### ART. 43070

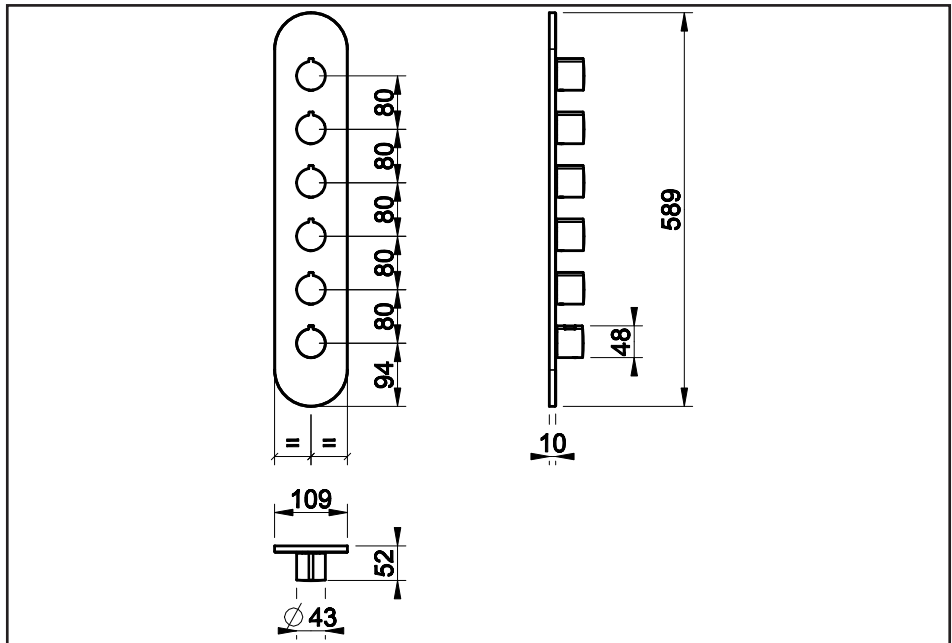



### ART. 43084

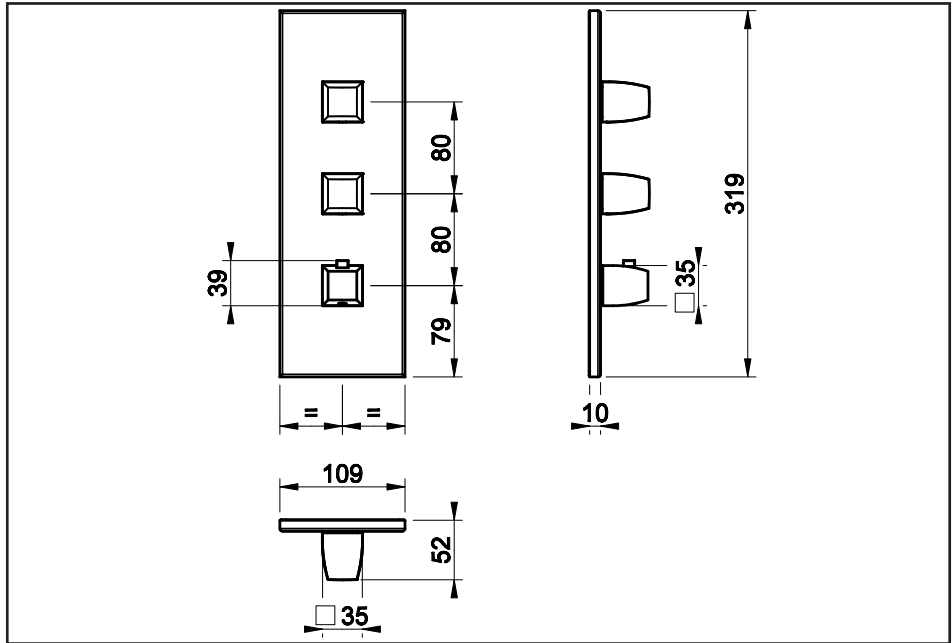

### ART. 43086

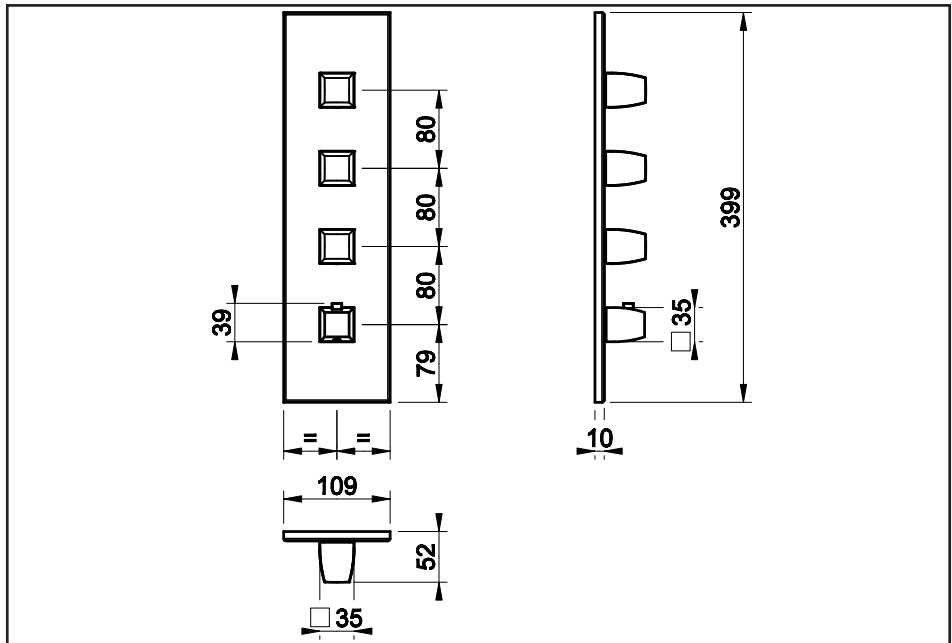



### ART. 43088

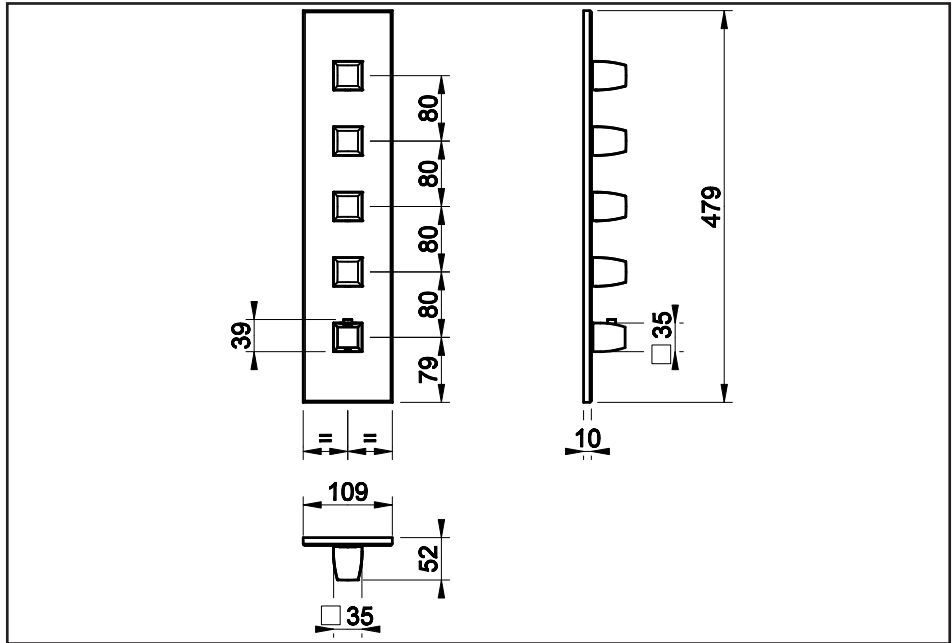

### ART. 43090

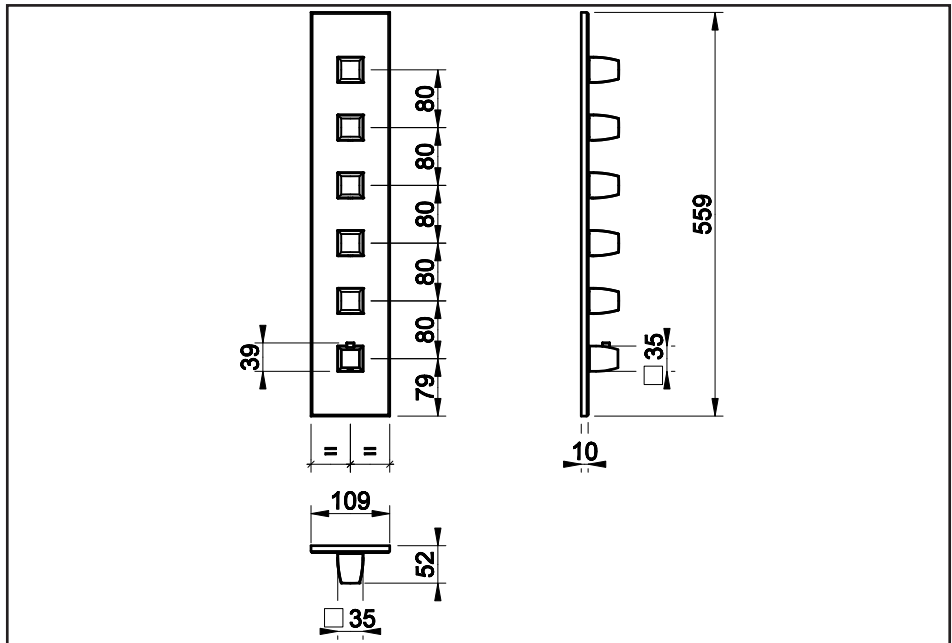



### ART. 45204

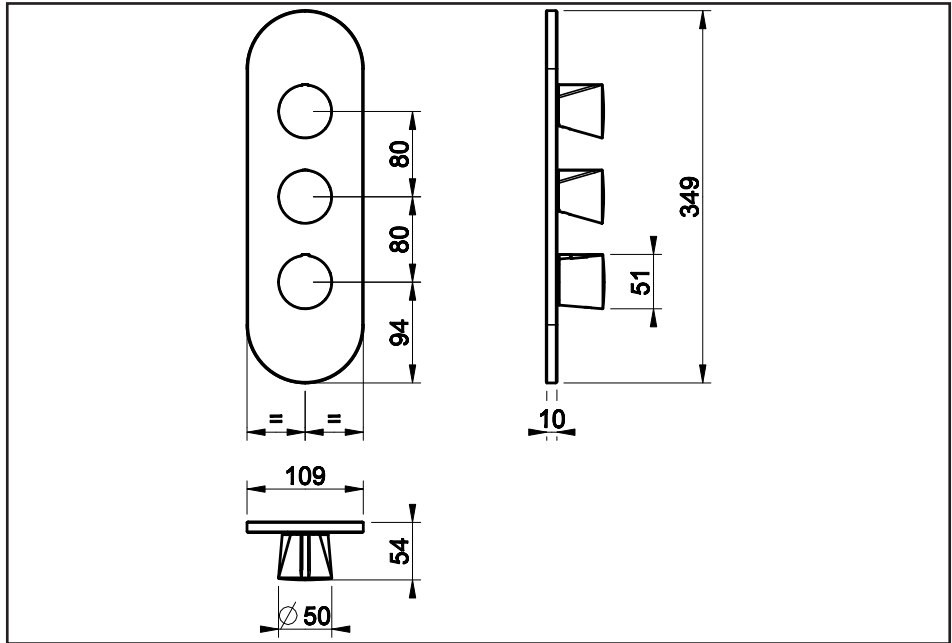

### ART. 45206

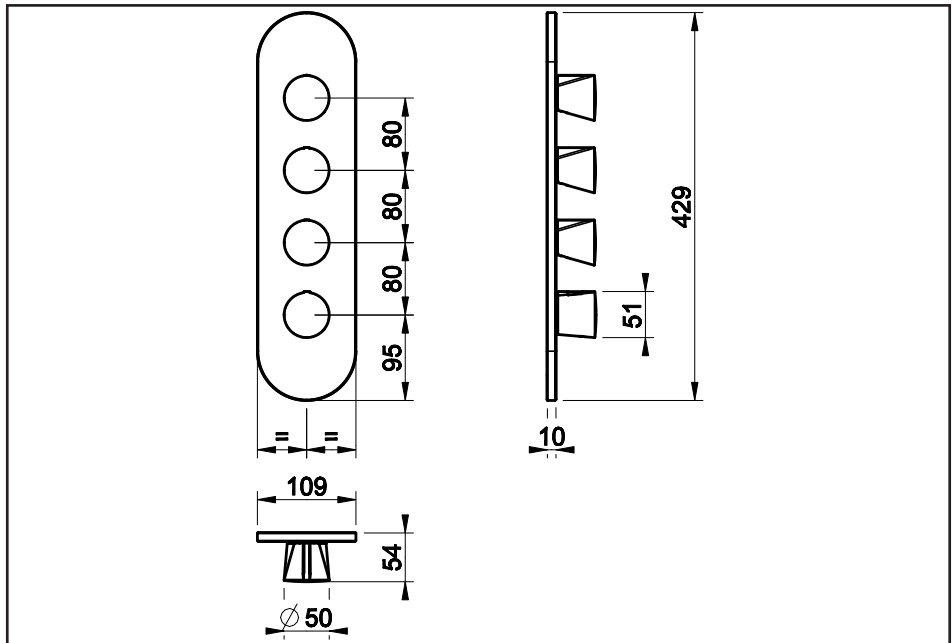



### ART. 45208

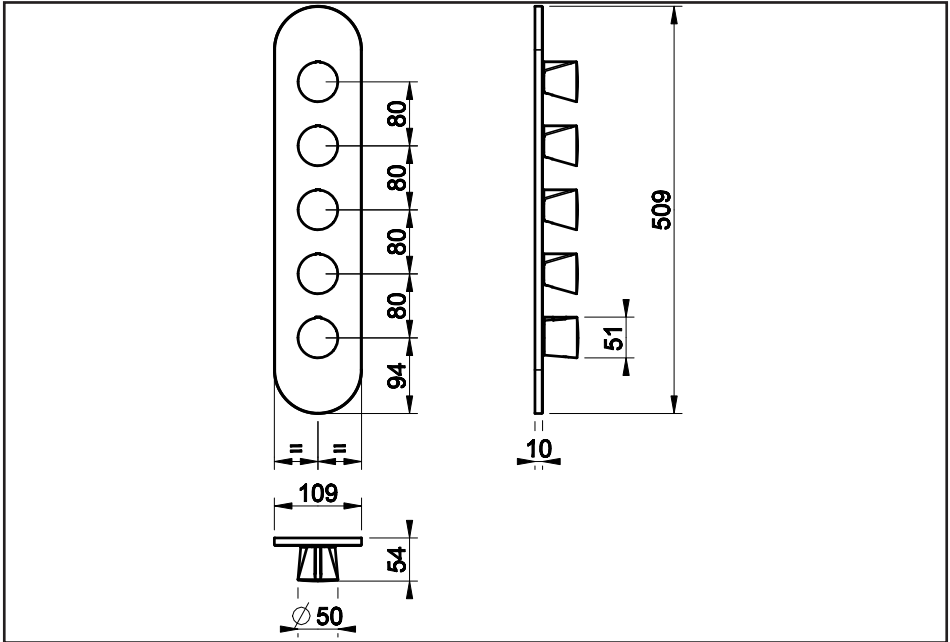

### ART. 45210

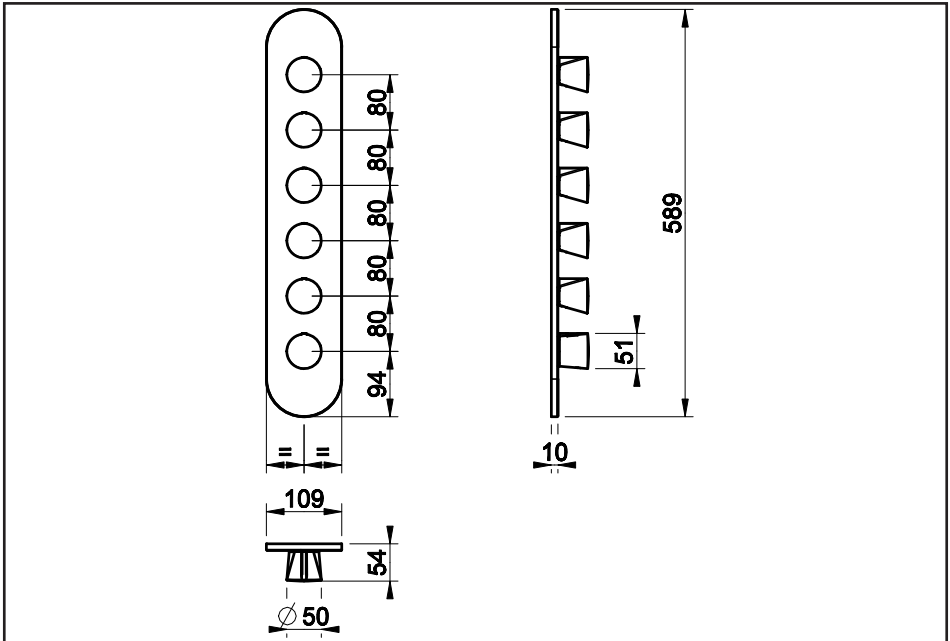



### ART. 46204

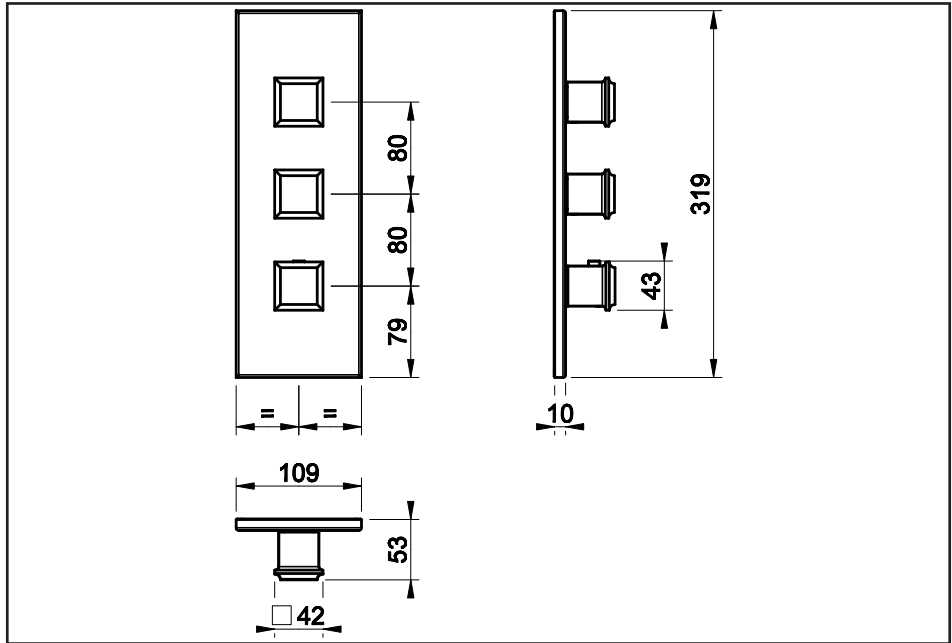

### ART. 46206

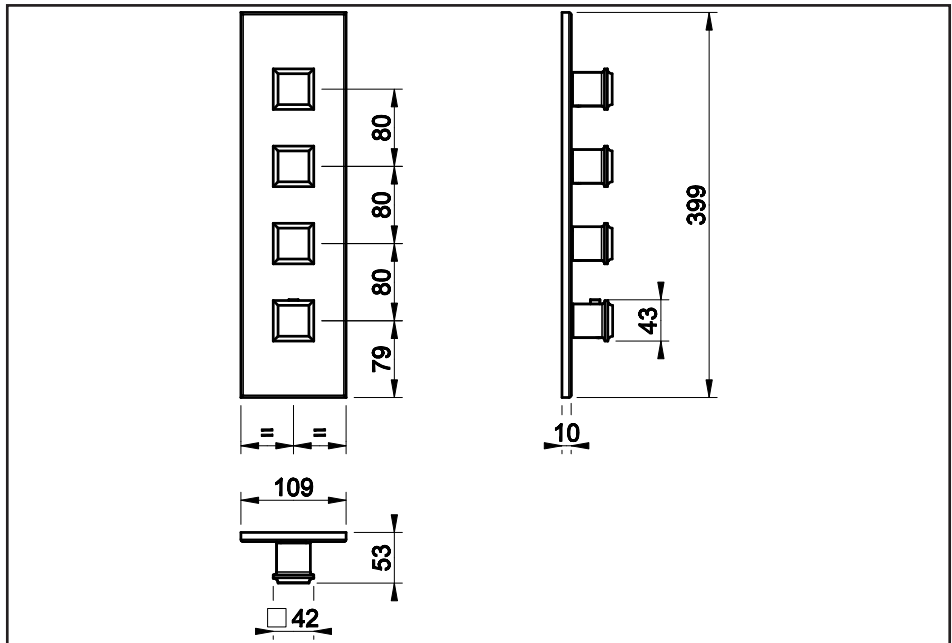



### ART. 46208

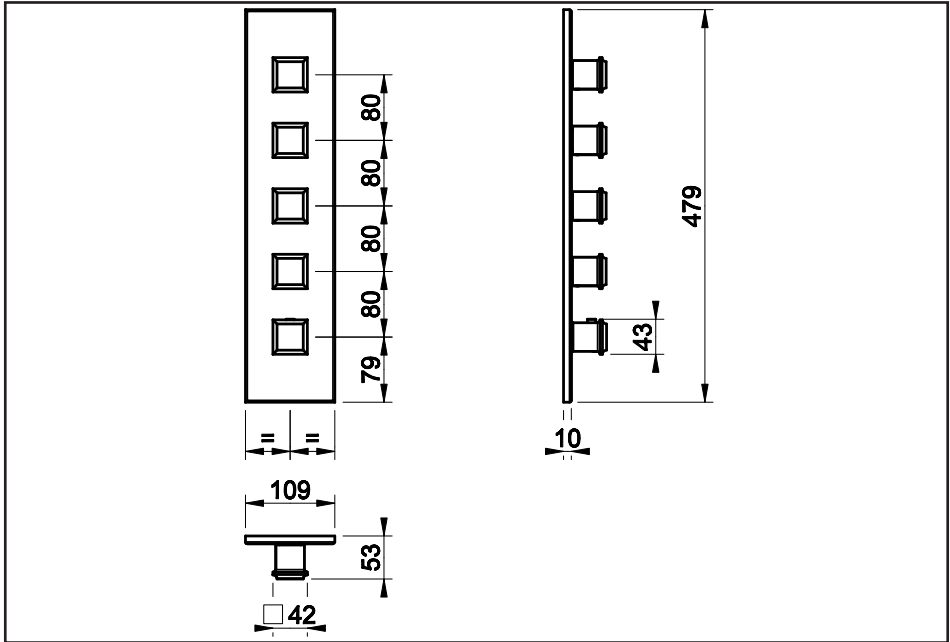

### ART. 46210

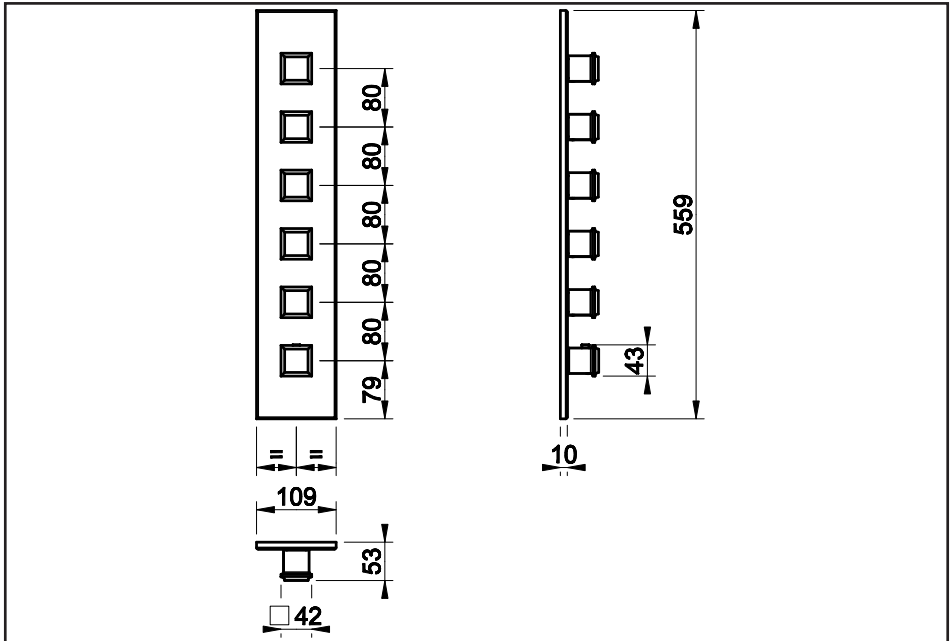



### ART. 58204

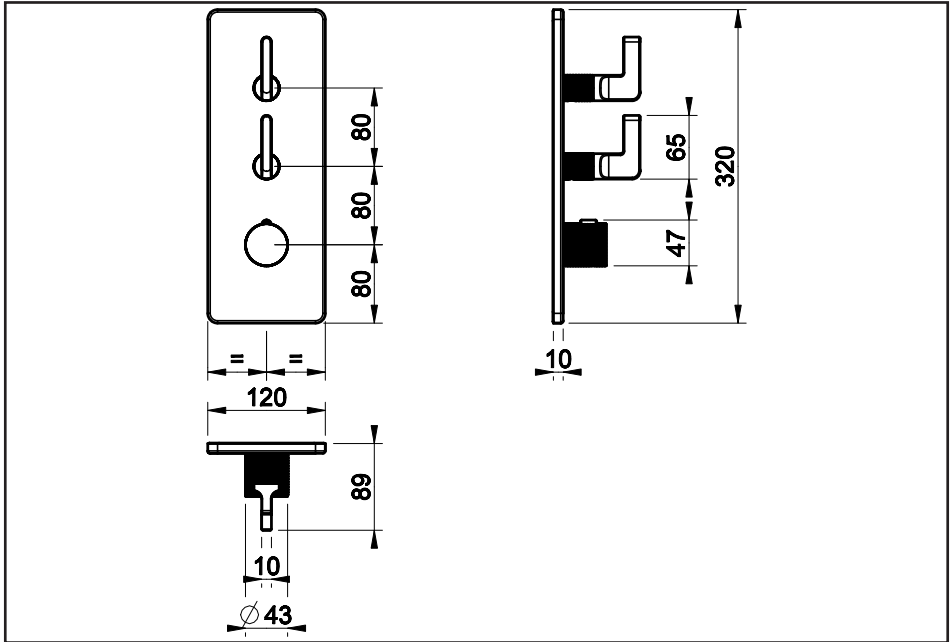

### ART. 58206

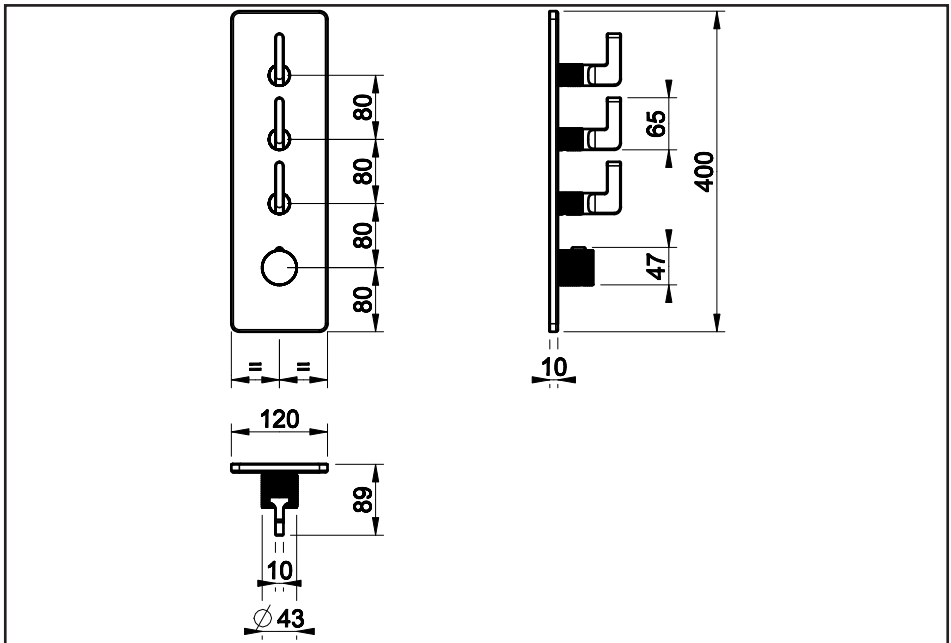



### ART. 58208

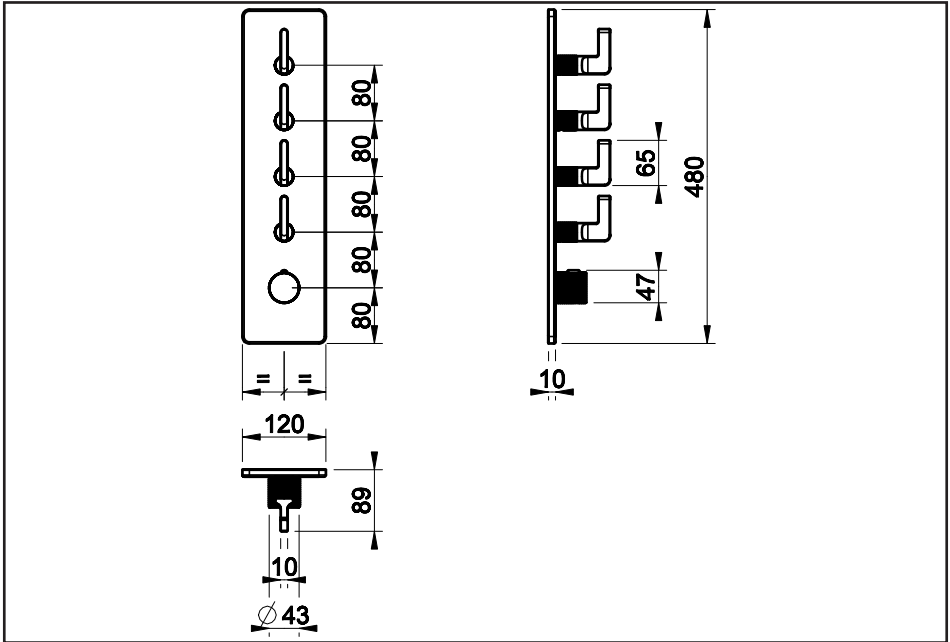

### ART. 58210

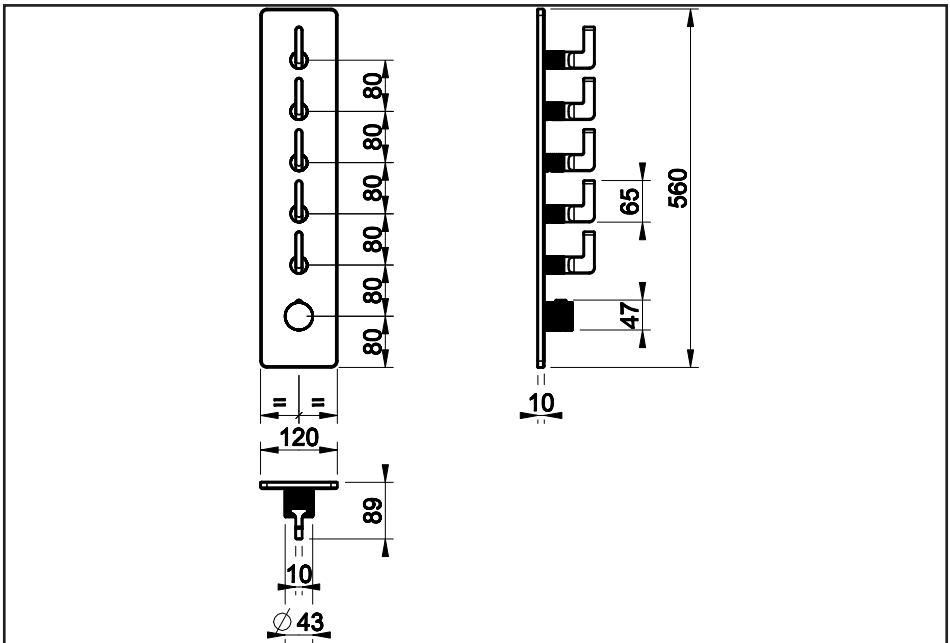



### ART. 58224

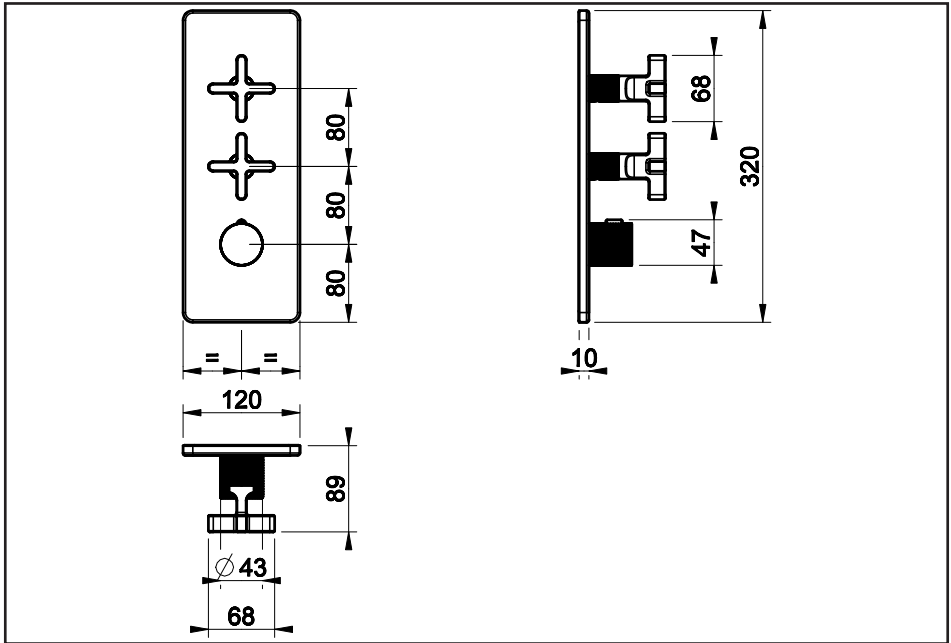

### ART. 58226

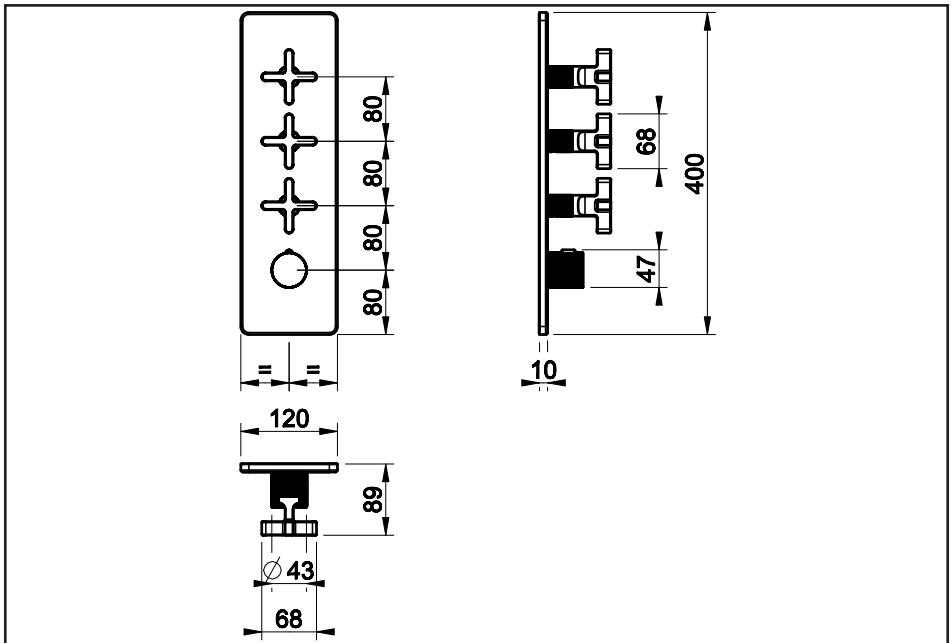



### ART. 58228

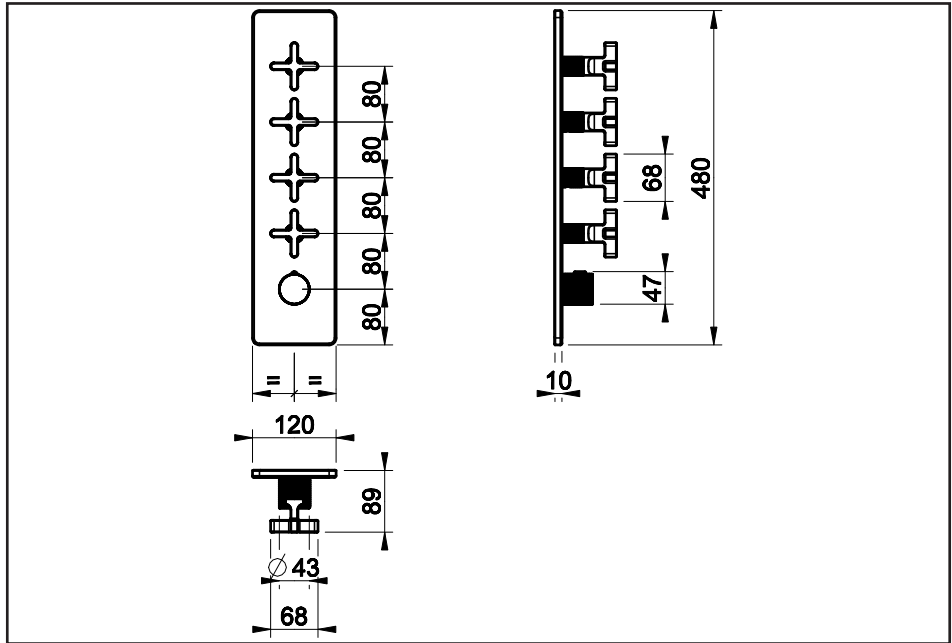

### ART. 58230

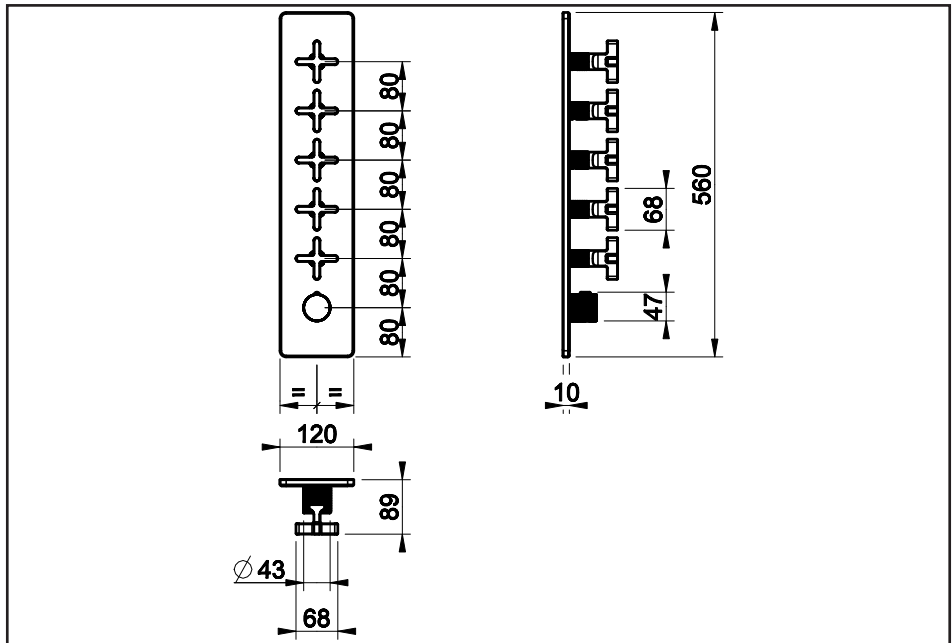



### ART. 65200

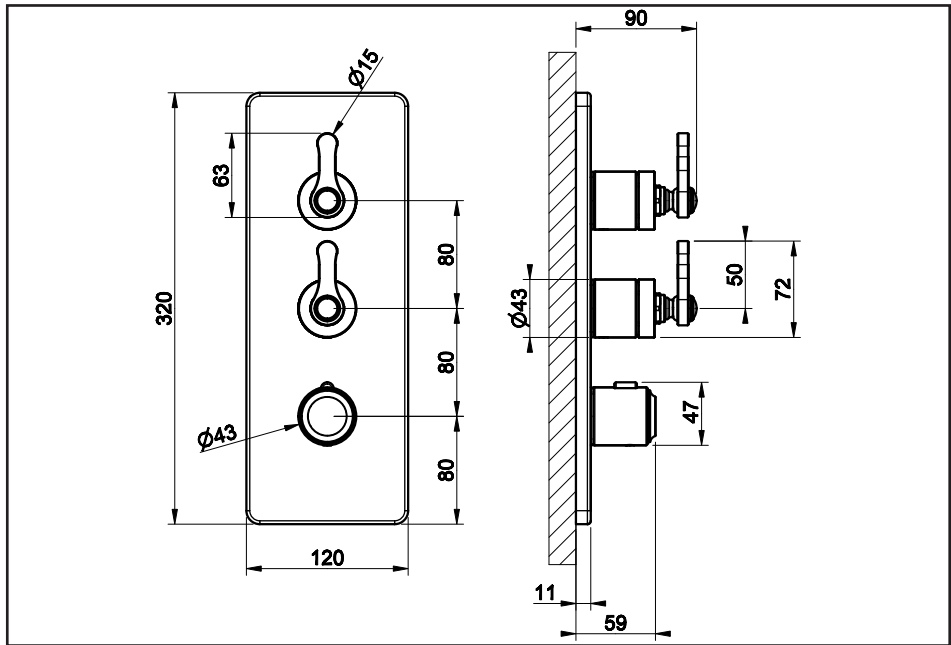

### ART. 65204

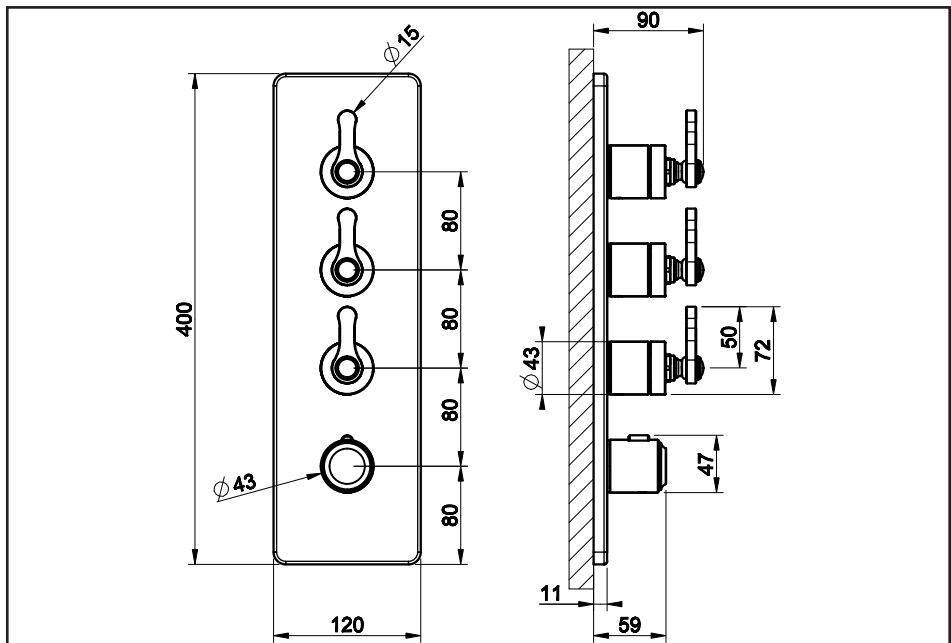



## ART. 65208

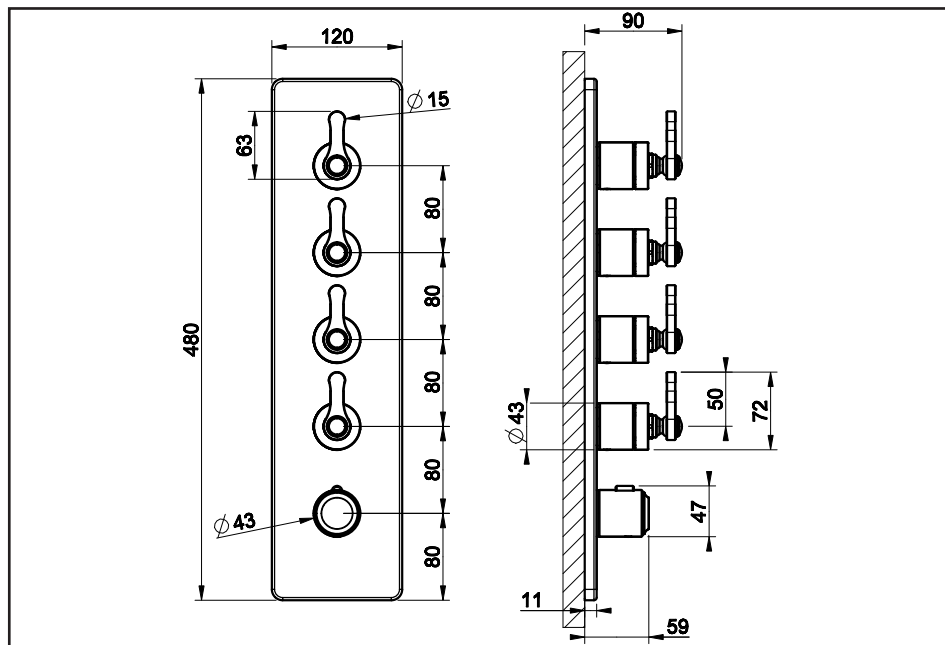



### ART. 75314

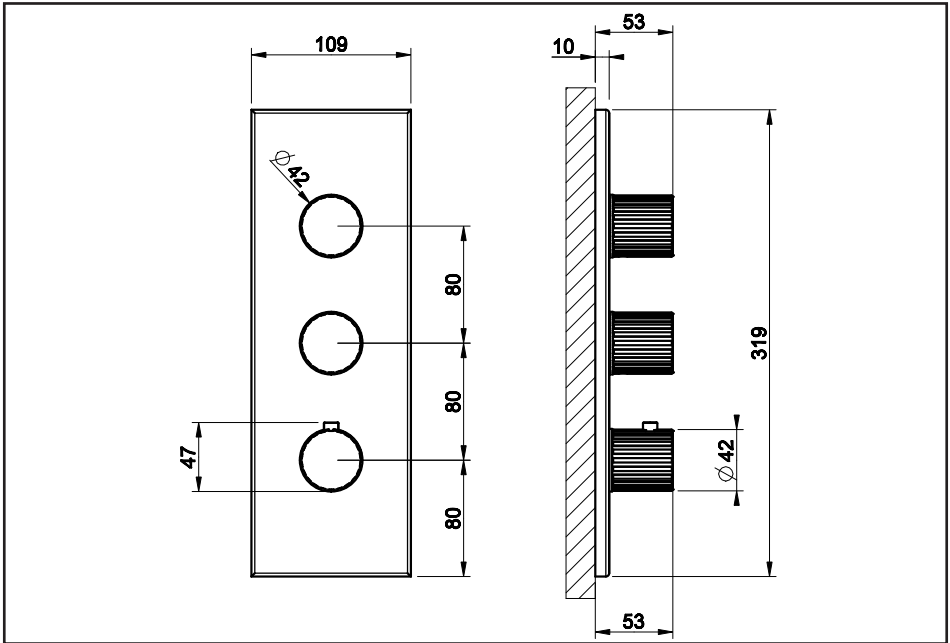

### ART. 75316

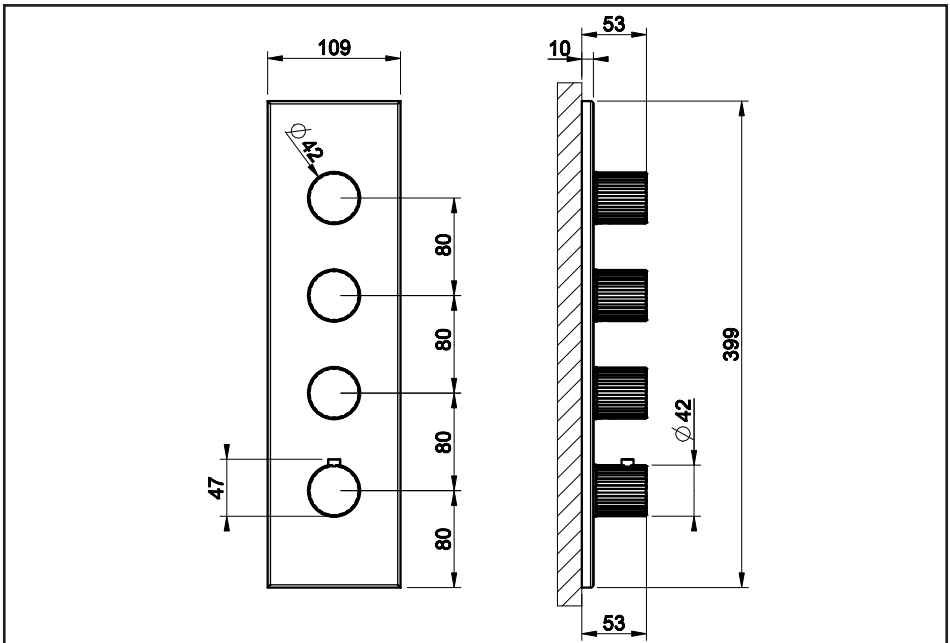



### ART. 75318

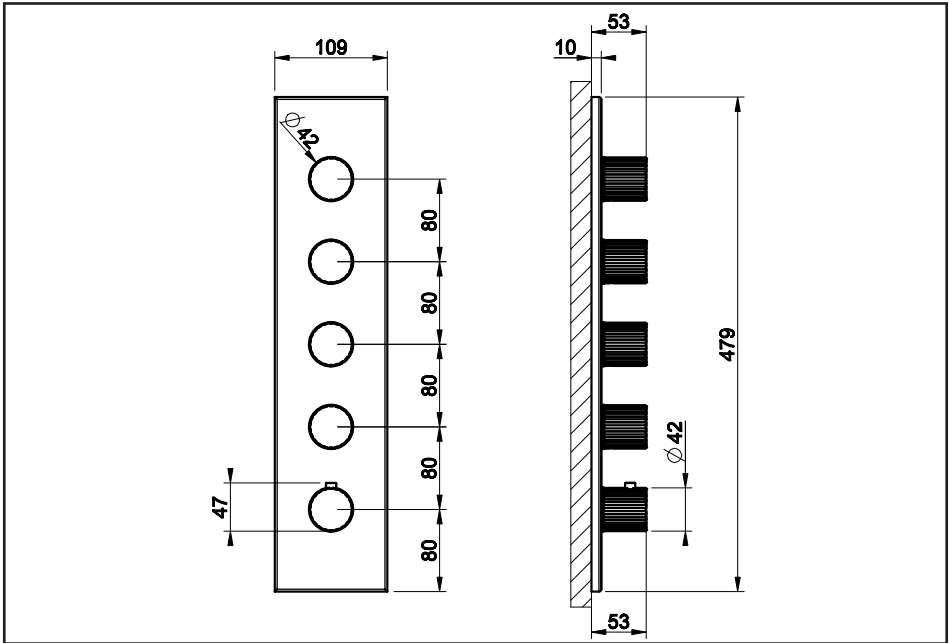

### ART. 75320

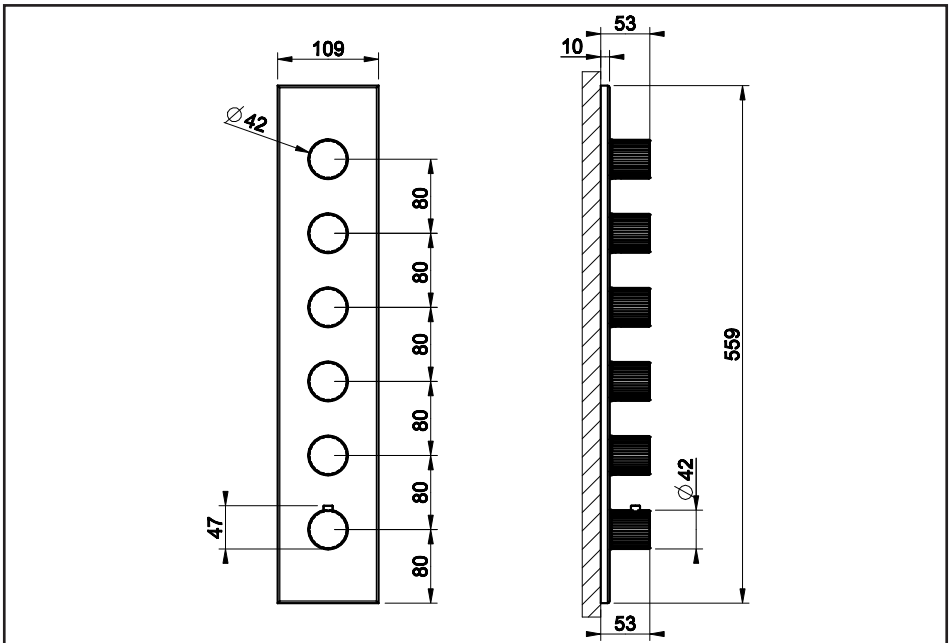



### **Prima dell'installazione e messa in funzione**

**Attenzione!** I tubi d'alimentazione devono essere sciacquati con cura prima dell'installazione del dispositivo, in modo che non rimangano trucioli, residui di saldatura o canapa, o altre impurità all'interno dei tubi. Attraverso tubazioni non sciacquate a fondo o attraverso la rete idrica generale, nel dispositivo possono entrare corpi estranei in grado di danneggiare guarnizioni/o-ring. Si raccomanda pertanto di dotare anche l'impianto generale di filtri.

#### **CARATTERISTICHE TECNICHE:**

- Blocco di sicurezza a 38°C
- Temperatura min. di esercizio 3°C - consigliata 15°C. - FREDDA
- Temperatura max di esercizio 80°C - consigliata 65°C. - CALDA
- Differenziale termico consigliato 50°C
- Sistema di sicurezza con blocco dell'erogazione in caso di mancanza di una delle due acque
- Pressione massima d'esercizio 5 bar
- Pressione d'esercizio consigliata 3 bar (in caso di pressione dell'acqua superiore ai 5 bar si consiglia l'installazione di riduttori di pressione)
- Per garantire il funzionamento ottimale del prodotto è importante che le pressioni in ingresso (acqua calda e acqua fredda) siano bilanciate con una differenza di pressione non superiore a  $\Delta p$  0,5 bar

#### **FUNZIONAMENTO:**

- Sia con scaldabagni a gas che elettrici ad accumulo
- Impianti centralizzati
- Caldaie murali
- Filtri per il trattamento delle impurità

**Attenzione: consultare il proprio idraulico di fiducia per la scelta del dispositivo di riscaldamento dell'acqua più idoneo.**

### **Before installation and setting to work**

**Attention!** The feeding pipes have to be rinsed carefully before the installation of the device so that there won't remain shavings, sealing or hemp residues, or other impurities inside the pipes. Through pipes not thoroughly rinsed or through the general water network, in the device foreign bodies can enter that could damage gaskets /o-ring. So filters should be installed also on the general system.

#### **TECHNICAL FEATURES:**

- Safety lock at 38°C
- Minimum working temperature 3°C - recommended 15°C - COLD
- Maximum working temperature 80°C - recommended 65°C - HOT
- Recommended thermal differential 50°C
- Safety system with flow stop in case of lack of one of the two waters
- Maximum working pressure 5 bar
- Recommended working pressure 3 bar (in case of water pressure higher than 5 bar it is recommended to install pressure reducers)
- To ensure that the product operates optimally, it is essential that the inlet pressures (hot and cold water) are balanced with a pressure difference of no more than a  $\Delta p$  of 0.5 bar

#### **OPERATION:**

- Either with gas or electric accumulation boilers
- Centralised systems
- Wall boilers
- Filters for impurity holding

**Warning: contact the plumber for the choice of the best water heating device.**

### **Avant l'installation et la mise en fonction**

**Attention!** Les tuyaux d'alimentation doivent être rincés avec soin avant l'installation du dispositif, de sorte que ils ne restent pas de copeaux, des restes de soudage ou de chanvre, ou d'autres impuretés à l'intérieur des tuyaux. A travers les conduites non rincées à fond ou à travers le réseau hydrique général, dans le dispositif peuvent entrer des corps étrangers à même de détériorer les gaines/o-ring. On recommande ainsi d'installer des filtres également sur le système général.

#### **CARACTÉRISTIQUES TECHNIQUES:**

- Bloc de sécurité à 38°C
- Température min. d'exercice 3°C - conseillée 15°C - FROIDE
- Température max. d'exercice 80°C - conseillée 65°C - CHAUDE
- Différentiel thermique conseillé 50°C
- Système de sécurité avec le bloc de la distribution en cas de manque d'une des deux eaux
- Pression maximum d'exercice 5 bar
- Pression d'exercice conseillée 3 bar (en cas de pression de l'eau supérieure aux 5 bar nous conseillons l'installation de réducteurs de pression)
- Pour garantir un fonctionnement optimal du produit, il est important que les pressions d'entrée (eau chaude et eau froide) soient équilibrées avec une différence de pression ne dépassant pas  $\Delta p$  0,5 bar

#### **FONCTIONNEMENT:**

- Soit avec des chauffe-eaux à gaz, électriques à accumulation
- Installations centrales
- Chaudières au mur
- Filtres pour la rétention des impuretés

**Attention: consulter le plombier pour le choix du dispositif de réchauffement de l'eau le plus approprié.**



### **Vor der Installation und Inbetriebnahme**

**Achtung!** Bevor die Vorrichtung zu installieren, bitte spülen Sie die Zuleitungsröhre sorgfältig aus, um alle Spannen, Schweiß- und Hanfrückstände bzw. alle Verunreinigungen vom Inneren der Röhre zu entfernen. Durch nicht sorgfältig gespülte Rohrleitungen bzw. durch das allgemeine Wassernetz können Fremdkörper in den Korpen eintreten, die die Dichtungen bzw. die O-Ringe beschädigen können. Es ist dann empfehlenswert, die allgemeine Anlage mit Filtern auszustatten.

#### **TECHNISCHE EIGENSCHAFTEN:**

- Sicherheitsblockierung bei 38°C
- Minimale Betriebstemperatur 3°C - empfehlenswert 15°C - KALT
- Maximale Betriebstemperatur 80°C - empfehlenswert 65°C - WARM
- Empfohlenes Thermodifferential 50°C
- Sicherheitssystem zum Unterbrechen der Wasserabgabe, sollte eine der beiden Wasserzuleitungen ausfallen
- Maximaler Betriebsdruck 5 bar
- Empfohlener Betriebsdruck 3 bar (sollte der Wasserdruck einen Wert von 5 bar überschreiten, empfiehlt es sich Druckminderventile zu installieren)
- Um einen optimalen Betrieb des Produkts zu gewährleisten, ist es wichtig, dass die Eingangsdrücke (Warm- und Kaltwasser) mit einer Druckdifferenz von höchstens  $\Delta p$  0,5 bar ausgeglichen sind

#### **FUNKTIONSTÄTIGKEIT:**

- Sowohl mit Gasbadeofen, als auch mit elektrischen Heißwasserspeichern
- Zentralisierte Anlagen
- Wandheizkessel
- Filter zum Zurückhalten von Verunreinigungen

**Achtung: zur Wahl der best anpassenden Wasserheizvorrichtung, bitte wenden Sie sich an Ihren Vertrauensinstallateur.**

### **Antes de la instalación y la puesta en función**

**¡Cuidado!** Los tubos de alimentación tienen que ser enjuagados escrupulosamente antes de instalar el dispositivo de manera que no haya virutas, residuos de soldadura o cáñamo u otras impurezas al interior de los tubos. A través de los tubos no perfectamente enjuagados o de la red hídrica general pueden entrar en el dispositivo unos cuerpos extraños que pueden dañar guarniciones/o-rings. Les recomendamos por lo tanto que instalen los filtros en la planta general también.

#### **CARACTERÍSTICAS TÉCNICAS:**

- Bloqueo de seguridad a 38°C
- Temperatura mín. de ejercicio 3°C - recomendada 15°C - FRÍA
- Temperatura máx. de ejercicio 80°C - recomendada 65°C - CALIENTE
- Diferencial térmico recomendado 50°C
- Sistema de seguridad con bloqueo de seguridad en caso de falta de una de las dos aguas
- Presión máxima de ejercicio 5 bar
- Presión de ejercicio aconsejada 3 bar (en caso de presión del agua superior a los 5 bar, les aconsejamos instalar unos reductores de presión)
- Para garantizar un funcionamiento óptimo del producto, es importante que las presiones de entrada (agua caliente y agua fría) estén equilibradas con una diferencia de presión no superior a  $\Delta p$  0,5 bar

#### **FUNCIONAMIENTO:**

- Con calderas tanto de gas como eléctricos por acumulación
- Instalaciones centralizadas
- Calderas murales
- Filtros para la retención de las impurezas

**Cuidado: consúltense con su fontanero para elegir el dispositivo de calefacción del agua más adecuado.**

### **Перед установкой и началом использования**

**Внимание!** Перед установкой смесителя необходимо тщательно промыть водопроводные трубы, чтобы в них не оставались стружка, шлак от сварки, лен или другие посторонние тела. Через плохо промытые водопроводные трубы или через общую водопроводную сеть в смеситель могут попасть посторонние тела, способные повредить уплотнения и уплотнительные кольца. Поэтому, рекомендуется оснастить фильтрами также и общую систему.

#### **ТЕХНИЧЕСКИЕ ХАРАКТЕРИСТИКИ:**

- Предохранительное ограничение температуры на 38°C
- Минимальная рабочая температура 3°C - рекомендованная 15°C - ХОЛОДНАЯ
- Максимальная рабочая температура: 80°C - рекомендованная 65°C - ГОРЯЧАЯ
- Рекомендуемая разница температуры: 50°C
- Предохранительная система с перекрытием подачи в случае отсутствия холодной или горячей воды
- Максимальное рабочее давление: 5 бар
- Рекомендованное рабочее давление 3 бар (в случае давления воды, превышающего 5 бар, рекомендуется установка редукторов давления)
- Для обеспечения оптимальной работы изделия важно, чтобы значения давления на входе (горячей и холодной воды) были сбалансированы, при этом разница значений не должна превышать  $\Delta p$  0,5 бар

#### **РАБОТА:**

- Как с газовыми водонагревателями, так и с электроводонагревателями накопительного типа
- Централизованные системы
- Настенные котлы
- Фильтры-ловители для удержания загрязненности

**Внимание: для выбора наиболее пригодного средства нагрева воды обращайтесь к вашему сантехнику.**



### Πριν από την εγκατάσταση και έναρξη της λειτουργίας

**Προσοχή!** Οι σωλήνες προφοδοσίας πρέπει να ξεπλένονται προσεχτικά πριν από την εγκατάσταση της μπαταρίας προκειμένου να αποφευχθεί η παρουσία ψηγμάτων, υπολειμμάτων συγκολλητικής ουσίας ή σκουπιού, ή άλλων ακαθαρσιών μέσα στους σωλήνες. Μέσα από όχι τέλεια καθαρισμένους σωλήνες ή μέσα από το γενικό δίκτυο παροχής νερού, στην μπαταρία μπορεί να εισχωρήσουν ξένα σώματα τα οποία μπορούν να προκαλέσουν ζημιά στα παρεμβύσματα / στους δακτύλιους κυκλικής διατομής. Έτσι λοιπόν θα πρέπει να τοποθετηθούν φίλτρα στο γενικό σύστημα.

#### **ΤΕΧΝΙΚΑ ΧΑΡΑΚΤΗΡΙΣΤΙΚΑ:**

- Εμπλοκή ασφαλείας στους 38°C
- Ελάχιστη θερμοκρασία λειτουργίας 3°C - συνιστώμενη 15°C - ΚΡΥΟ
- Μέγιστη θερμοκρασία λειτουργίας 80°C - συνιστώμενη 65°C - ΖΕΣΤΟ
- Συνιστώμενο θερμικό διαφορικό 50°C
- Σύστημα ασφαλείας με εμπλοκή της παροχής σε περίπτωση απουσίας του ενός από τα δύο νερά
- Μέγιστη πίεση λειτουργίας 5 bar
- Συνιστώμενη πίεση λειτουργίας 3 bar (σε περίπτωση πίεσης του νερού μεγαλύτερη από 5 bar συνιστάται η τοποθέτηση μειωτήρων πίεσης)
- Για την εξασφάλιση της βέλτιστης λειτουργίας του προϊόντος, οι εισερχόμενες πιέσεις (ζεστό νερό και κρύο νερό) είναι σημαντικό να εξισορροπούνται με διαφορά πίεσης όχι πάνω από Δp 0,5 bar

#### **ΛΕΙΤΟΥΡΓΙΑ:**

- Είτε με θερμοσίφωνες αερίου είτε με ηλεκτρικούς συσσωρεύσεις
- Κεντρικές μονάδες
- Λέβητες τοίχου
- Φίλτρα για την συγκράτηση των ακαθαρσιών

**Προσοχή: συμβουλευτείτε τον υδραυλικό της εμπιστοσύνης σας για την επιλογή της πιο κατάλληλης διάταξης θέρμανσης του νερού.**

### **在安装和使用前**

**小心!** 安装本设备之前需要仔细清洗水管，确保管道里面不残留金属屑、焊接后的残渣或麻丝，或者是其他脏物。异质也能通过未深度冲洗的水管或更广义的水网管道进入装置，从而损坏垫圈/O形密封圈。为此建议为总水管网配置过滤器。

#### **技术参数:**

- 38°C 安全模块
- 最小工作温度3°C-建议温度15°C—冷水
- 最大工作温度80°C-建议温度65°C—热水
- 建议温差为50°C
- 缺少冷水或热水时启用停止出水的系统
- 最大工作压力为5巴
- 建议采用的工作压力为3巴（如果水压超过5巴建议安装减压阀）
- 为确保产品的最佳运行状态，进水压力（热水和冷水）必须保持平衡，压差不超过 Δp 0.5巴

#### **运行:**

- 可用燃气热水器或蓄热式电热水器
- 中央设备系统
- 壁挂式锅炉
- 杂质处理过滤器

**注意: 请咨询可信赖的水工以选择最合适的水加热设备。**



**ATTENZIONE:** la rappresentazione dell'installazione del miscelatore termostatico è stata basata solo sull'articolo a 2 uscite essendo la medesima per tutti i prodotti precedentemente elencati.

**WARNING:** the representation of the installation of the thermostatic mixer is based only on item with 2 outlets since it is the same for all previously mentioned products.

**ATTENTION:** la représentation de l'installation du mitigeur thermostatique se base seulement sur l'article à 2 sorties étant la même pour tous les produits énumérés auparavant.

**ACHTUNG:** Die Darstellung für die Installation der thermostatischen Mischbatterie stützt sich nur auf den Artikel mit 2 Ausgängen, da diese für alle zuvor aufgeführten Produkte gleich ist.

**CUIDADO:** la representación de la instalación del mezclador termostático se basa en la referencia de 2 salidas, con ser ésta la misma para todos los productos anteriormente mencionados.

**ВНИМАНИЕ:** изображение установки термостатического смесителя было основано только на артикуле с 2 выходами, поскольку она одинакова для всех перечисленных выше артикулов.

**ΠΡΟΣΟΧΗ:** η απεικόνιση της εγκατάστασης της θερμοστατικής αναμικτικής μπαταρίας βασίστηκε μόνο στο προϊόν με 2 εξόδους καθώς είναι η ίδια για όλα τα προϊόντα που έχουν αναφερθεί προηγουμένως.

**注意:** 因为以前产品都采用同样方式，恒温混水器安装演示仅采用双出口产品。

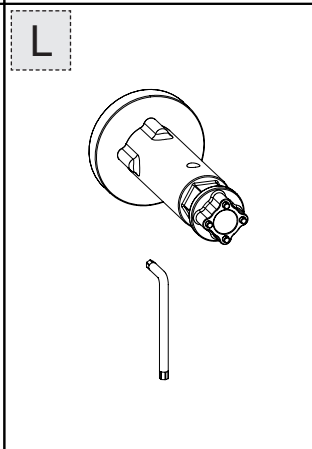
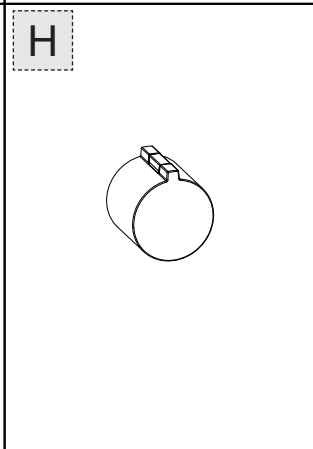
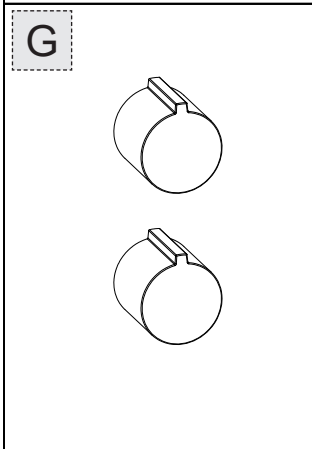
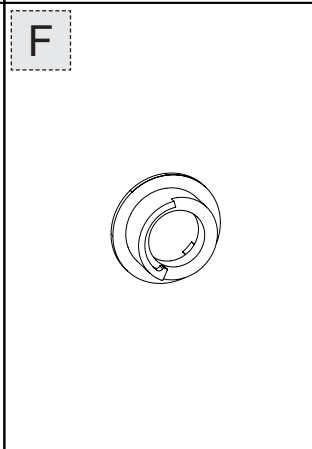
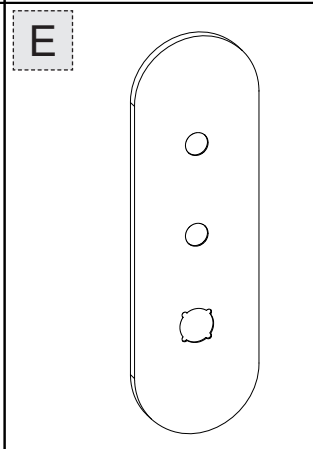
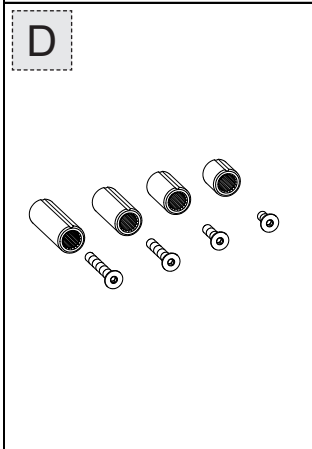
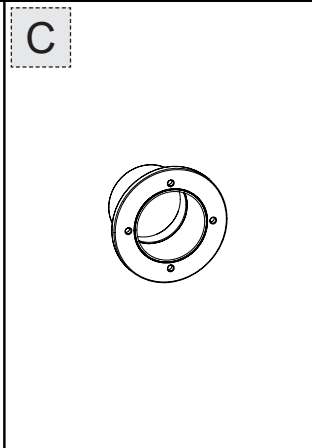
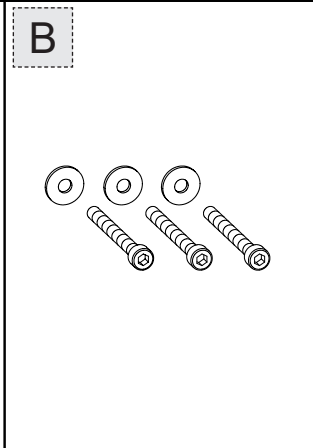
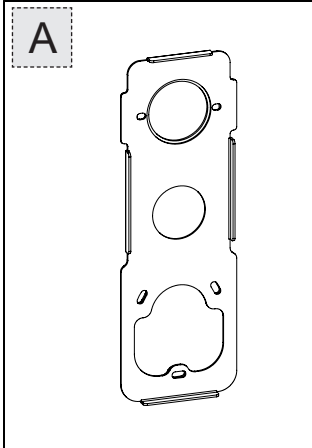



**Contenuto della confezione:**

- A - Piastra di fissaggio
- B - Viti di fissaggio piastra
- C - Boccola per fissaggio piastra
- D - Kit prolunga
- E - Piastra in finitura
- F - Fermo di regolazione della temperatura
- G - Maniglia di comando
- H - Maniglia per regolazione temperatura
- L - Chiavi per l'installazione

**Package content:**

- A - Fastening plate
- B - Plate fastening screws
- C - Bush for plate fastening
- D - Extension set
- E - Finish plate
- F - Temperature adjustment stop
- G - Control handle
- H - Handle for temperature adjustment
- L - Installation wrenches

**Contenu de l'emballage:**

- A - Plaque de fixation
- B - Vis de fixation plaque
- C - Douille pour fixation plaque
- D - Jeu rallonge
- E - Plaque en finition
- F - Arrêts de réglage de la température
- G - Poignée de commande
- H - Poignée réglage température
- L - Clés pour l'installation

**Inhalt der Verpackung:**

- A - Befestigungsplatte
- B - Befestigungsschrauben für die Platte
- C - Buchse für die Befestigung der Platte
- D - Bausatz Ansatzstück
- E - Abschlussplatte
- F - Feststellvorrichtung für die Temperatureinstellung
- G - Steuergriff
- H - Griff zur Temperatureinstellung
- L - Schlüssel für die Installation

**Contenido de la caja:**

- A - Placa de fijación
- B - Tornillos de fijación plancha
- C - Buje para fijación placa
- D - Juego extensión
- E - Placa de acabado
- F - Retén de regulación de la temperatura
- G - Maneta de mando
- H - Maneta para la regulación de la temperatura
- L - Llaves de instalación

**Содержимое упаковки:**

- A - Крепежная пластина
- B - Крепежные винты пластины
- C - Втулка для закрепления плитки
- D - Комплект удлинителя
- E - Декоративная пластина
- F - Регулировочный стопор температуры
- G - Ручка управления
- H - Регулировочная ручка температуры
- L - Ключи для установки

**Περιεχόμενο συσκευασίας:**

- A - Πλάκα στερέωσης
- B - Βίδες στερέωσης πλάκας
- C - Έδρανο στερέωσης πλάκας
- D - Kit προέκτασης
- E - Πλάκα φινιρίσματος
- F - Στοπ ρύθμισης της θερμοκρασίας
- G - Λαβή εντολής
- H - Λαβή για ρύθμιση θερμοκρασίας
- L - Κλειδιά για την εγκατάσταση

**包装内含:**

- A - 固定面板
- B - 板用紧固螺钉
- C - 板固定衬套
- D - 加长套件
- E - 装饰面板
- F - 温度调节手柄锁止器
- G - 控制手柄
- H - 温度调节手柄
- L - 安装用扳手



Fig. 1

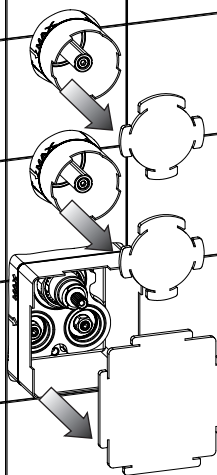

Fig. 2

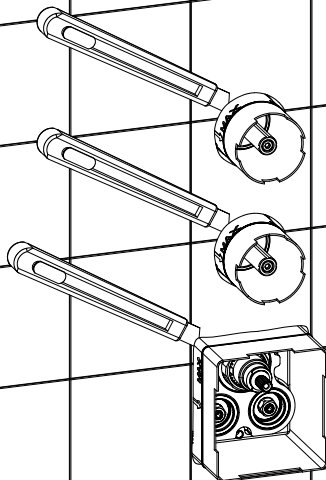

Fig. 3

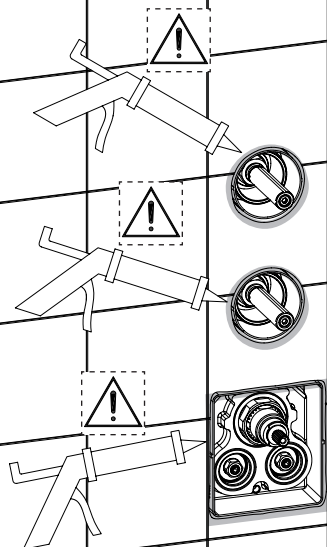
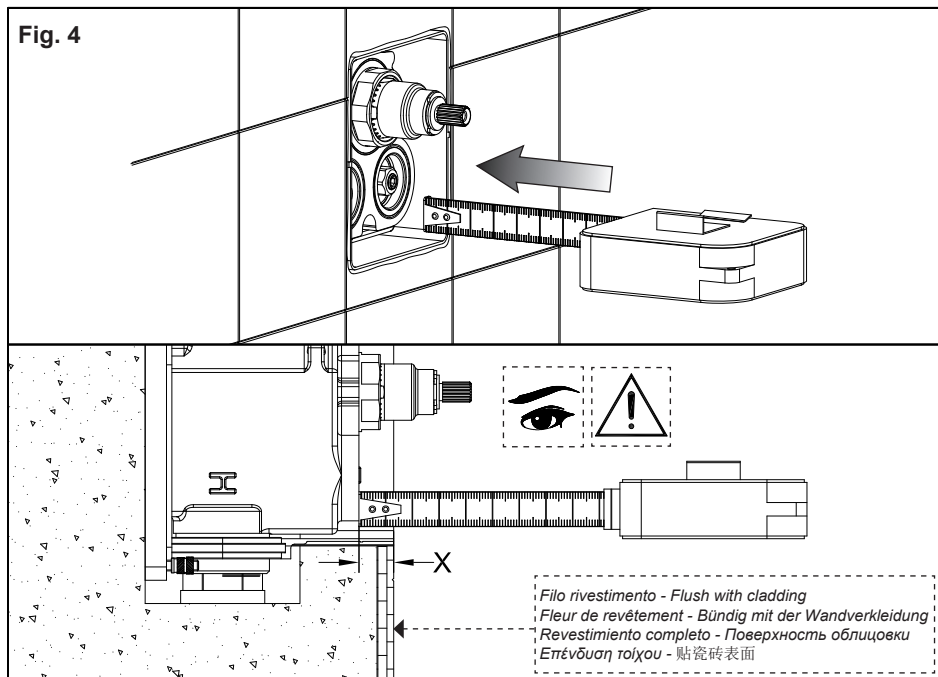

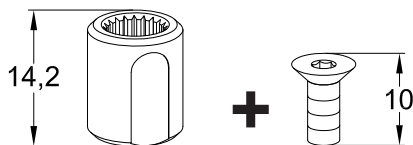

Fig. 4





**0mm ÷ 3mm**



**3mm ÷ 10mm**

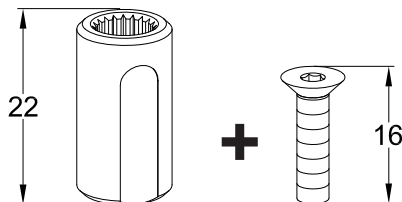

**10mm ÷ 17mm**

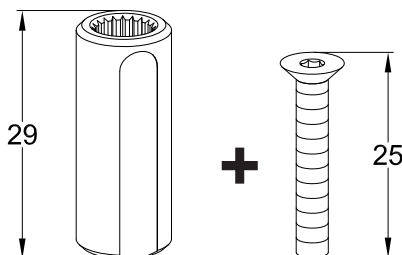

**17mm ÷ 25mm**

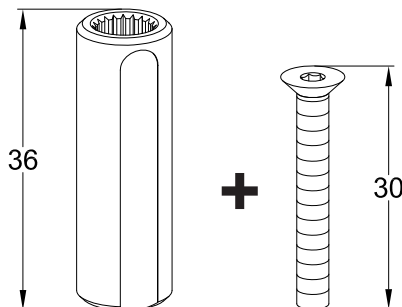



**Fig. 5**

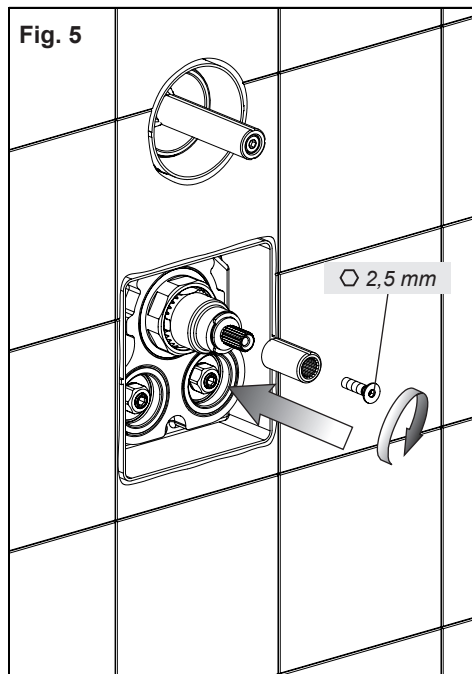

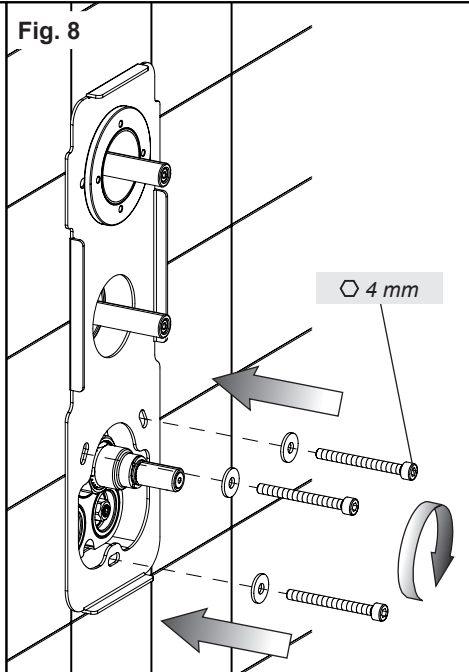
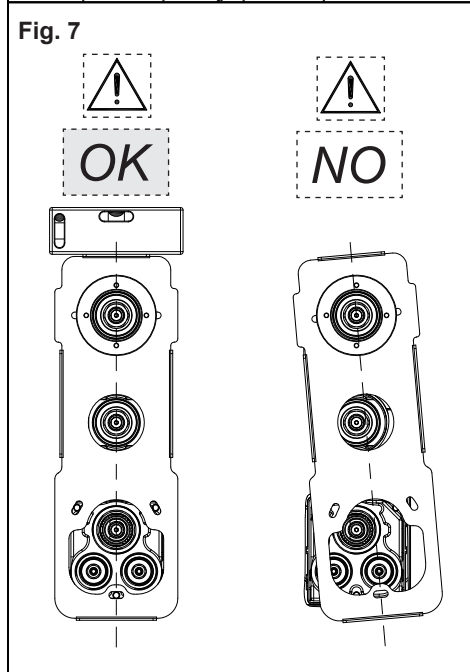
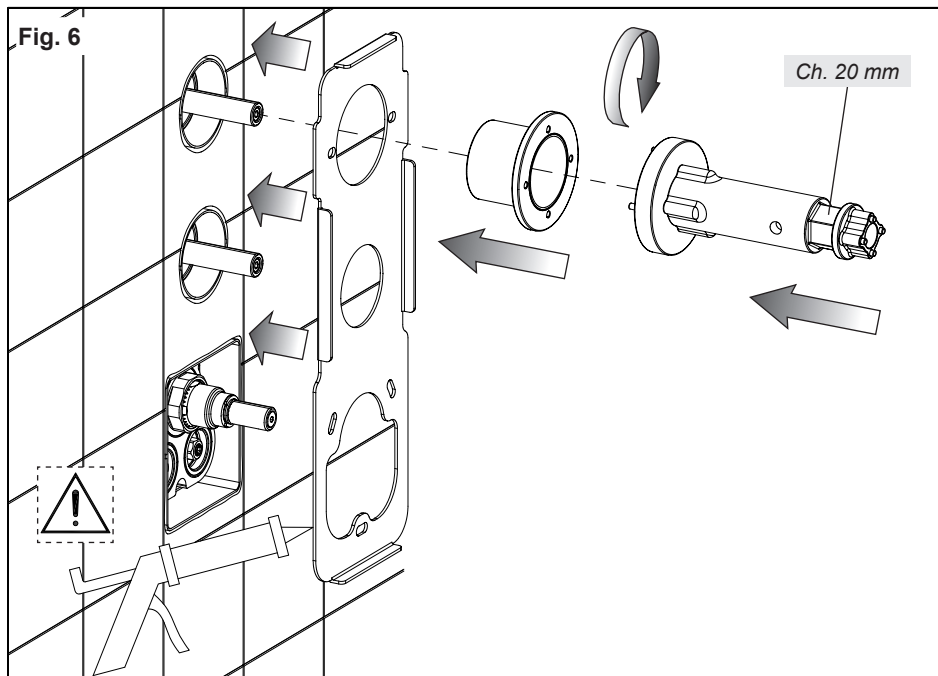



Fig. 9

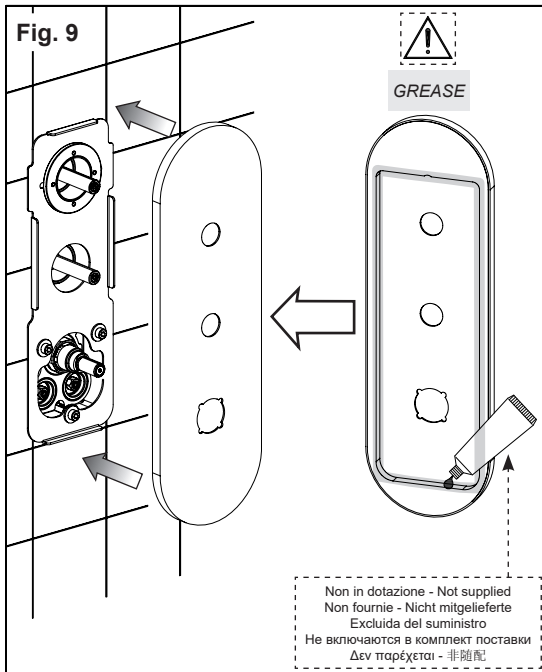

Fig. 10

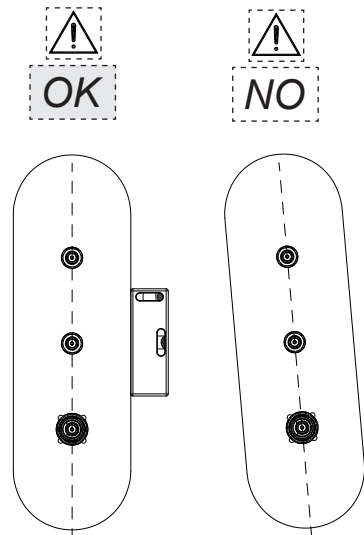

Fig. 11

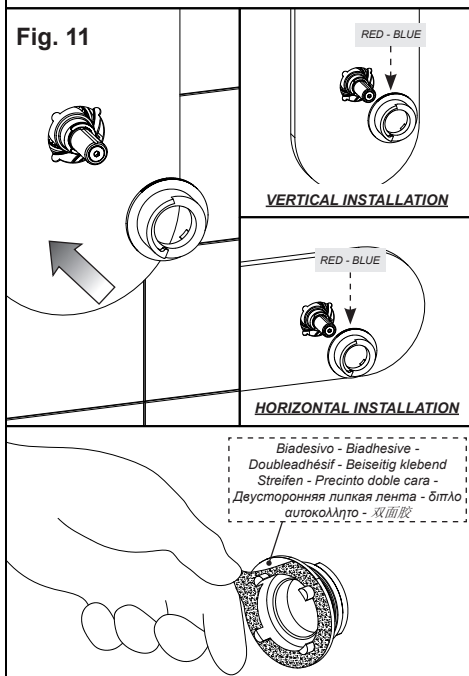



Fig. 12

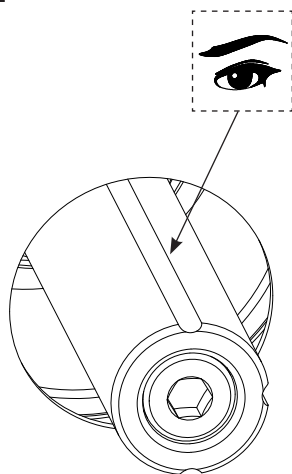

Fig. 13

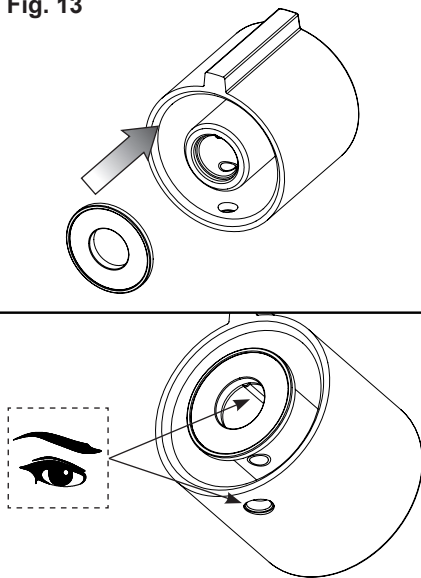

Fig. 14

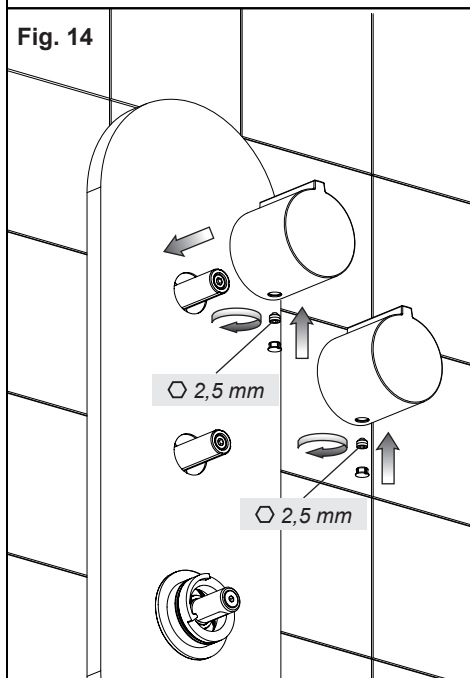

Fig. 15

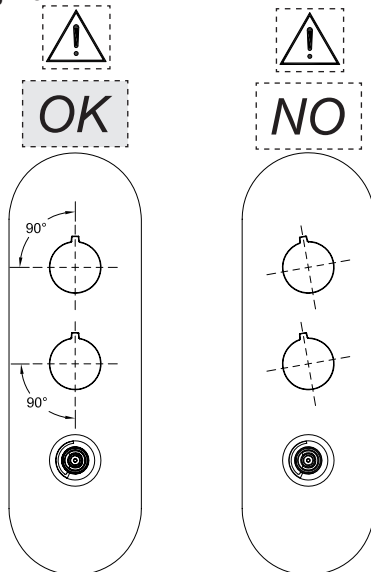
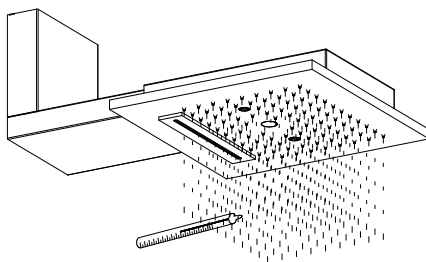
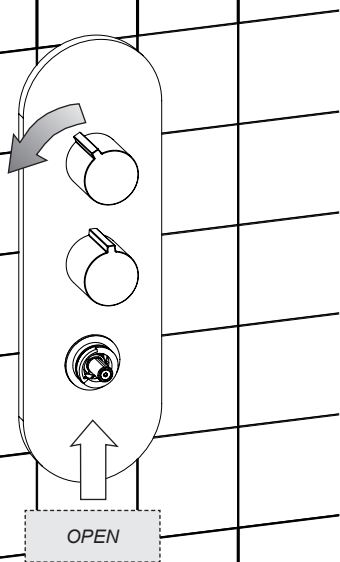

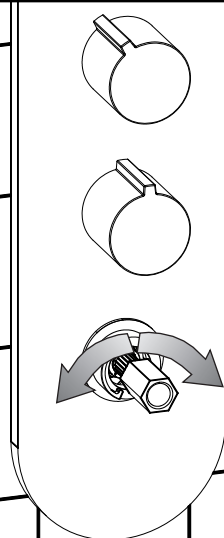

Fig. 16



~~38°C~~

Fig. 17



○ 17 mm

Fig. 18

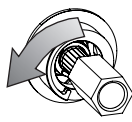

+

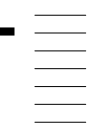

38°C



-





Fig. 19

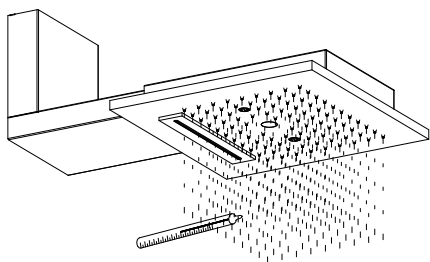

38°C



Fig. 20

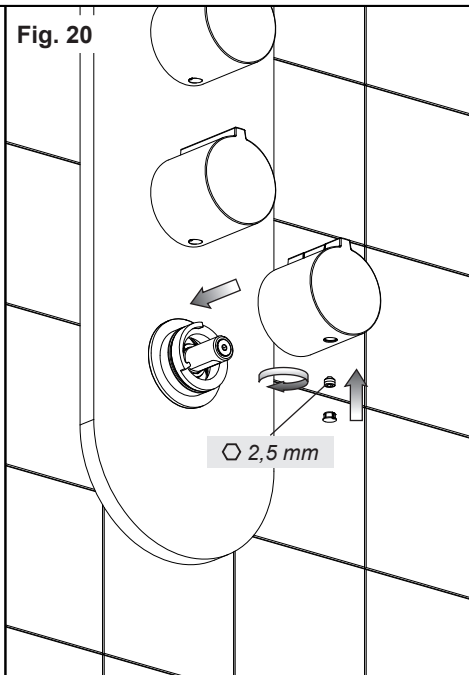
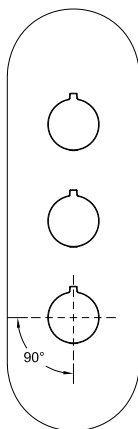

Fig. 21



OK



NO

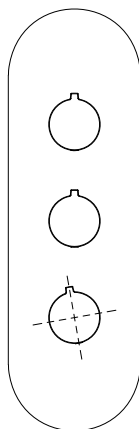



**ATTENZIONE!**

*L'installazione del miscelatore termostatico incasso è terminata, prima dell'utilizzo visionare la sezione relativa al funzionamento riportata nelle pagine seguenti.*

**WARNING!**

*The installation of the built-in thermostatic mixer is over, before use read the section concerning the operation in the following pages.*

**ATTENTION!**

*L'installation du mitigeur thermostatique encastrément est terminée, avant l'emploi voir la section relative au fonctionnement dans les pages suivantes.*

**ACHTUNG!**

*Die Installation der eingebauten, thermostatischen Mischbatterie ist abgeschlossen. Bevor man diese benutzt, schaut man sich den Abschnitt bezüglich der Funktionstätigkeit auf den folgenden Seiten an.*

**¡CUIDADO!**

*La instalación del mezclador termostático por empotrar se ha acabado; antes de su utilización consulten la sección relativa al funcionamiento proporcionada en las páginas a continuación.*

**ВНИМАНИЕ!**

*Установка встроенного термостатического смесителя завершена, перед началом использования прочитайте раздел, касающийся работы, приведенный на следующих страницах.*

**ΠΡΟΣΟΧΗ!**

*Η εγκατάσταση της θερμοστατικής αναμικτικής μπαταρίας έχει ολοκληρωθεί, πριν από τη χρήση δείτε το μέρος που αφορά τη λειτουργία που παρατίθεται στις ακόλουθες σελίδες.*

**注意!**

*嵌入式恒温混水器安装结束了，使用前请阅读下面几页上有关运行的部分*

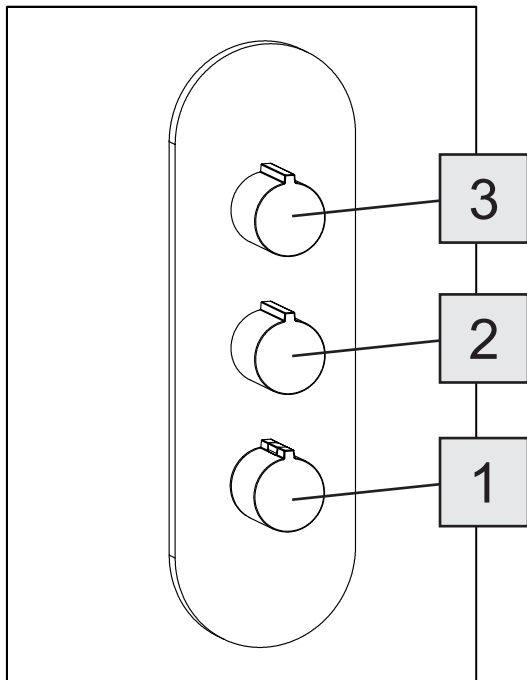

1	Comando per la regolazione della temperatura - Temperature adjustment control - Commande pour le réglage de la température - Steuerung für die Temperatureinstellung - Mando para la regulación de la temperatura - Регулятор температуры - Εντολή για τη ρύθμιση της θερμοκρασίας - 温度控制装置
2	Comando di apertura uscita N°1 - Opening control outlet N°1 - Commande d'ouverture sortie N°1 - Öffnungssteuerung von Ausgang N°1 - Mando de abertura salida N°1 - Кран открытия выхода N°1 - Εντολή ανοίγματος εξόδου N°1 - 出口开启开关1
3	Comando di apertura uscita N°2 - Opening control outlet N°2 - Commande d'ouverture sortie N°2 - Öffnungssteuerung von Ausgang N°2 - Mando de abertura salida N°2 - Кран открытия выхода N°2 - Εντολή ανοίγματος εξόδου N°2 - 出口开启开关2



1

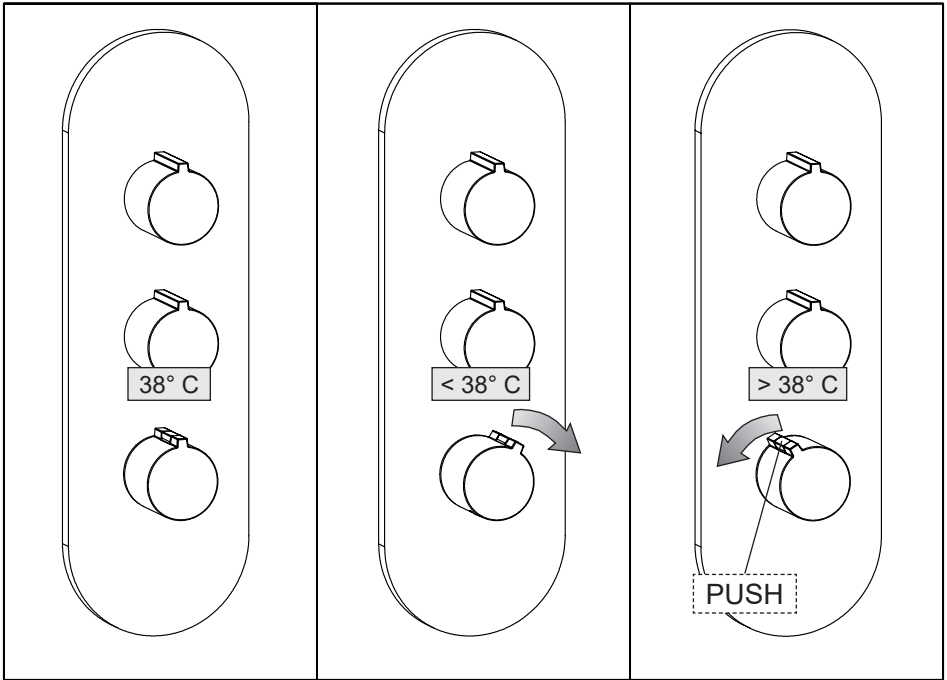



2-3

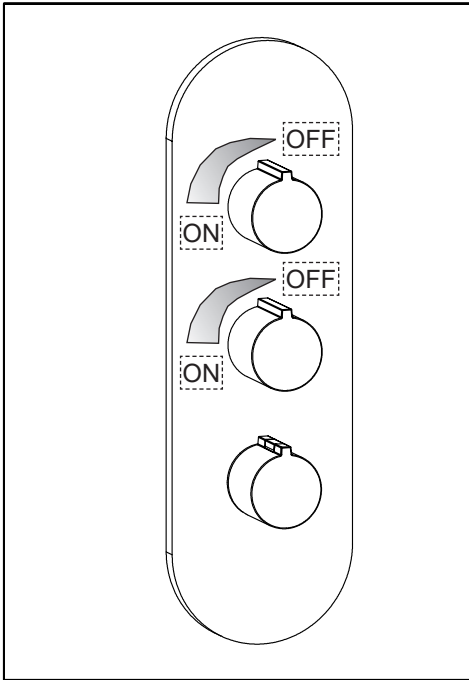

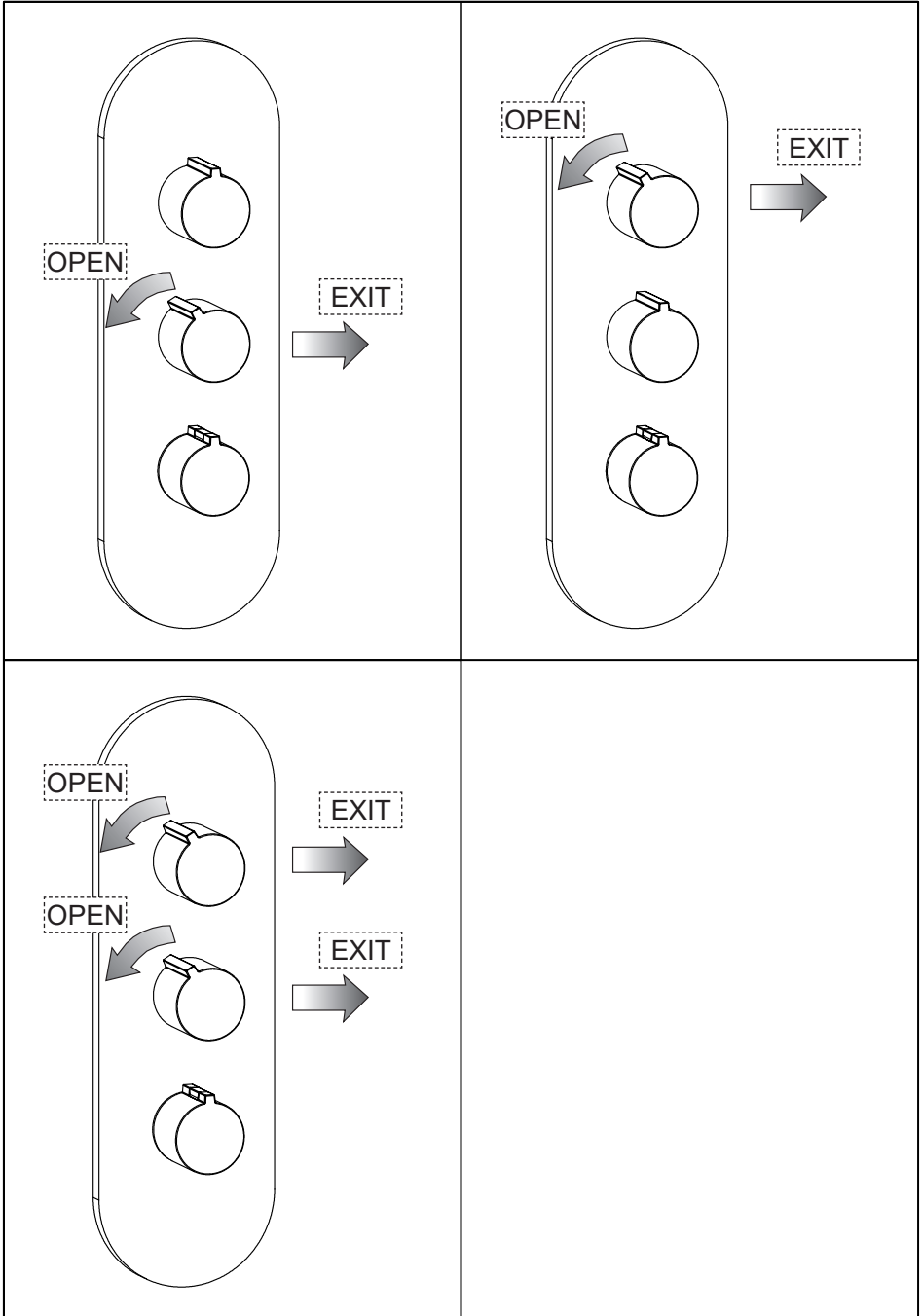



#### **MANUTENZIONE**

- Nel caso sia necessario sostituire uno o più componenti, contattare un rivenditore autorizzato o visitare il sito [WWW.GESSI.COM](http://WWW.GESSI.COM)
- Affidare la manutenzione del prodotto a personale qualificato

#### **MAINTENANCE**

- Should it be necessary to replace one or more components, contact an authorized retailer or visit [WWW.GESSI.COM](http://WWW.GESSI.COM)
- Product maintenance should be made only by qualified staff

#### **ENTRETIEN**

- S'il est nécessaire de remplacer un ou plusieurs composants, contacter un centre autorisé ou visiter le site [WWW.GESSI.COM](http://WWW.GESSI.COM)
- L'entretien du produit ne doit être effectué que par du personnel qualifié

#### **WARTUNG**

- Falls das Auswechseln von einem oder mehreren Bestandteilen erforderlich wird, kontaktieren Sie bitte einen autorisierten Fachhandel oder besuchen Sie unsere Website unter [WWW.GESSI.COM](http://WWW.GESSI.COM)
- Die Instandhaltung des Produktes sollte nur qualifiziertem Personal anvertraut werden.

#### **MANUTENCIÓN**

- En el caso de que sea necesario remplazar uno o más componentes, contacten con un revendedor autorizado o visiten el sitio [WWW.GESSI.COM](http://WWW.GESSI.COM)
- Encarguen sólo a personal calificado para el mantenimiento del producto

#### **ОБСЛУЖИВАНИЕ**

- В случае если будет необходимо заменить один или несколько компонентов, обратитесь к авторизованному дистрибьютору или посетите веб-сайт [WWW.GESSI.COM](http://WWW.GESSI.COM)
- Обслуживание изделия должен выполнить квалифицированный персонал.

#### **ΣΥΝΤΗΡΗΣΗ**

- Σε περίπτωση που είναι απαραίτητο να αντικαταστήσετε ένα ή περισσότερα εξαρτήματα, επικοινωνήστε με ένα εξουσιοδοτημένο κατάστημα πώλησης ή επισκεφθείτε τον ιστότοπο [WWW.GESSI.COM](http://WWW.GESSI.COM)
- Εμπιστευθείτε τη συντήρηση του προϊόντος σε διαπιστευμένο προσωπικό

#### **保养**

- 若需替换一个或者多个部件，请联系授权分销商或浏览[WWW.GESSI.COM](http://WWW.GESSI.COM)网站
- 请让合格人士负责产品保养工作



Fig. 1

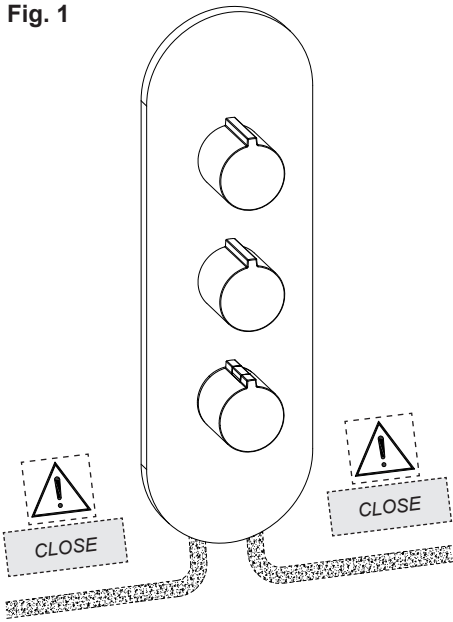

Fig. 2

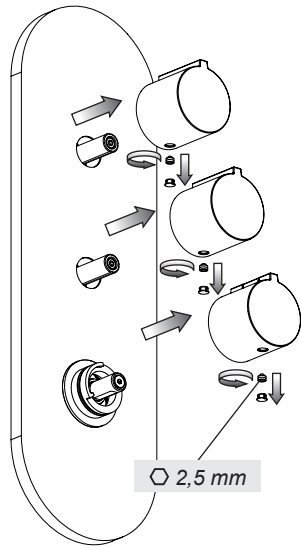

Fig. 3

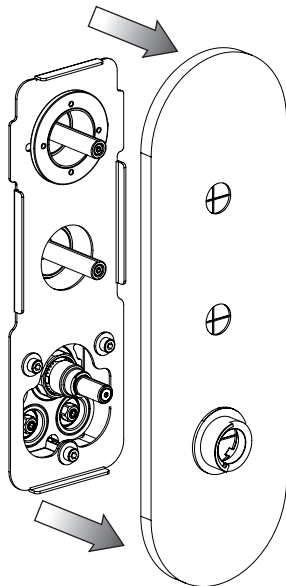

Fig. 4

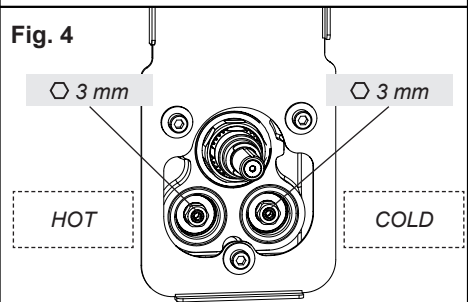
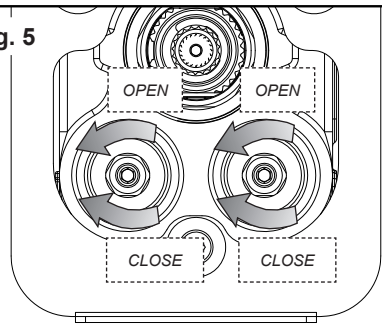

Fig. 5





SOSTITUZIONE DEL VITONE - HEADVALVE REPLACEMENT - SUBSTITUTION DE LA TÊTE - AUSTAUSCHEN DES OBERTEILS -  
 SUSTITUCIÓN DE LA MONTURA - ЗАМЕНА ЗАТВОРА - ΑΝΤΙΚΑΤΑΣΤΑΣΗ ΤΗΣ ΒΙΔΑΣ - 更换瓣旋式阀门

Fig. 1

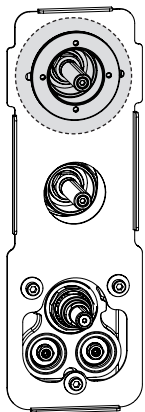

Fig. 2

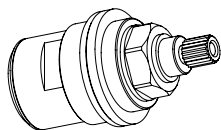
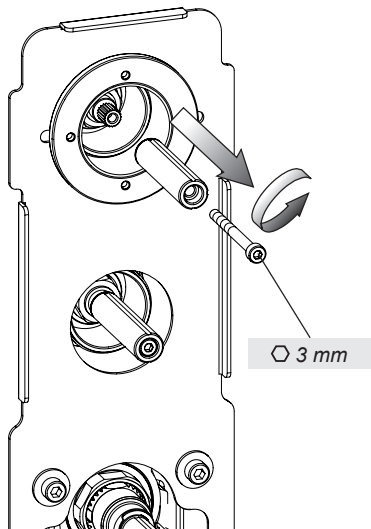
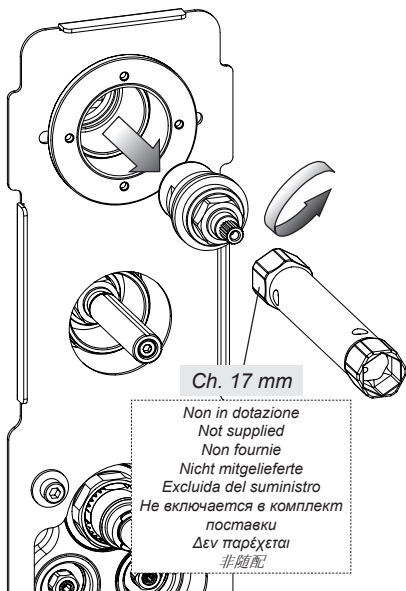

Fig. 3



Ch. 17 mm

Non in dotazione  
 Not supplied  
 Non fournie  
 Nicht mitgelieferte  
 Excluida del suministro  
 Не включается в комплект  
 поставки  
 Δεν παρέχεται  
 非随配



ALLINEAMENTO DELLE MANIGLIE DI COMANDO - ALIGNMENT OF CONTROL HANDLES - ALIGNEMENT DES POIGNÉES DE  
COMMANDE - AUSRICHTEN DER STEUERGRIFFE - ALINEACIÓN DE LAS MANETAS DE MANDO - ВЫРАВНИВАНИЕ РУЧЕК  
УПРАВЛЕНИЯ - ΕΥΘΥΓΡΑΜΜΙΣΗ ΤΩΝ ΛΑΒΩΝ ΕΝΤΟΛΗΣ - 控制手柄的对位

Fig. 1

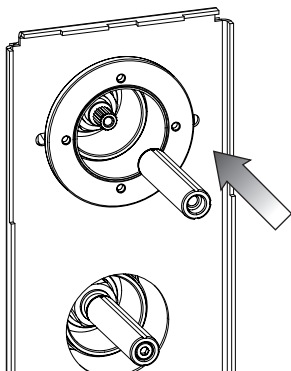

Fig. 2

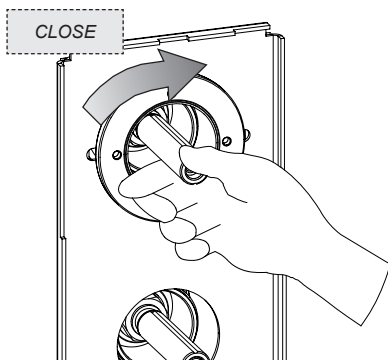

Fig. 3

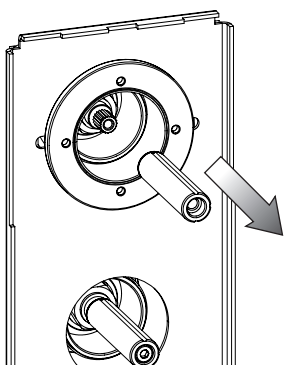

Fig. 4

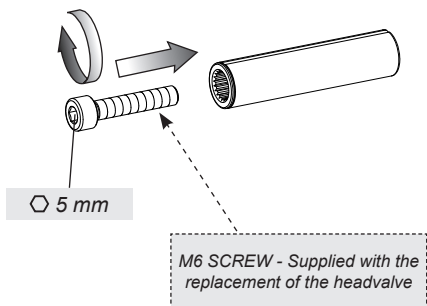

Fig. 5

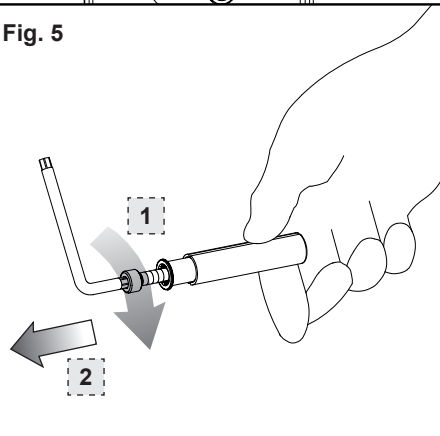
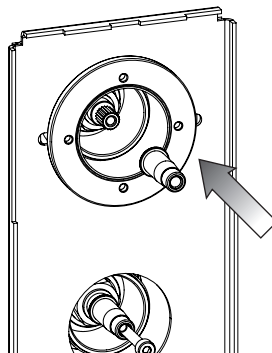

Fig. 6





ALLINEAMENTO DELLE MANIGLIE DI COMANDO - ALIGNMENT OF CONTROL HANDLES - ALIGNEMENT DES POIGNÉES DE  
COMMANDE - AUSRICHTEN DER STEUERGRIFFE - ALINEACIÓN DE LAS MANETAS DE MANDO - ВЫРАВНИВАНИЕ РУЧЕК  
УПРАВЛЕНИЯ - ΕΥΘΥΓΡΑΜΜΙΣΗ ΤΩΝ ΛΑΒΩΝ ΕΝΤΟΛΗΣ - 控制手柄的对位

Fig. 7

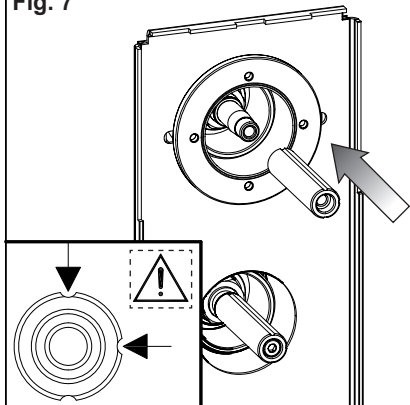

Fig. 8

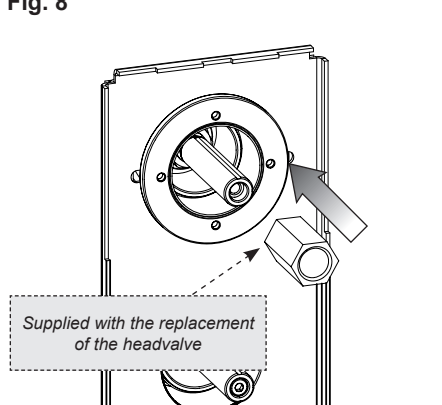

Fig. 9

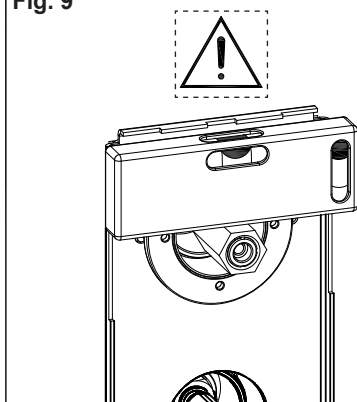

Fig. 10

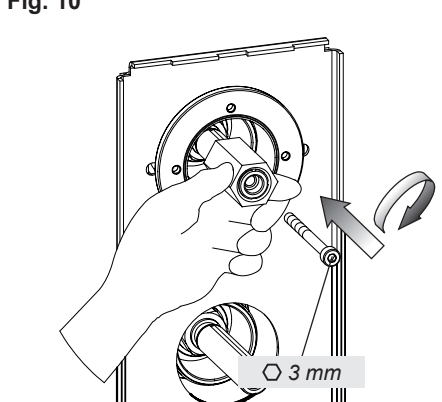

Fig. 11

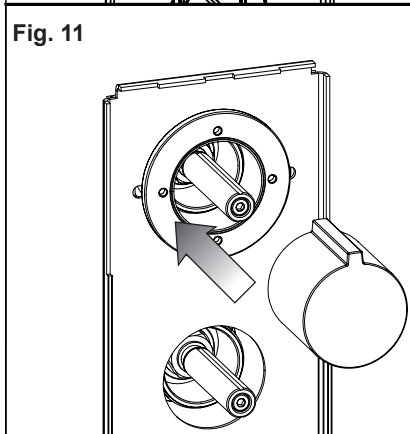
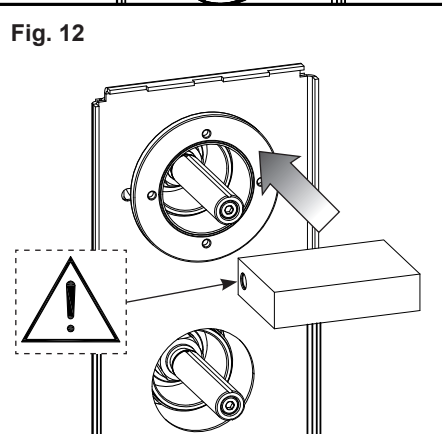

Fig. 12





ALLINEAMENTO DELLE MANIGLIE DI COMANDO - ALIGNMENT OF CONTROL HANDLES - ALIENEMENT DES POIGNÉES DE  
COMMANDE - AUSRICHTEN DER STEUERGRIFFE - ALINEACIÓN DE LAS MANETAS DE MANDO - ВЫРАВНИВАНИЕ РУЧЕК  
УПРАВЛЕНИЯ - ΕΥΘΥΓΡΑΜΜΙΣΗ ΤΩΝ ΛΑΒΩΝ ΕΝΤΟΛΗΣ - 控制手柄的对位

Fig. 13

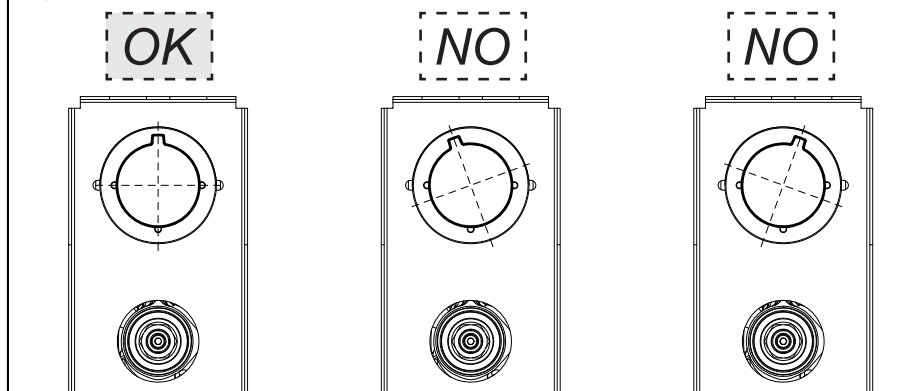

Ripetere questi passaggi fino ad ottenere il corretto allineamento della maniglia, infine togliere la stessa per permettere l'installazione delle parti esterne.

Repeat these steps until reaching proper alignment of the handle, and then remove it to allow the installation of external parts.

Repeat these steps until reaching proper alignment of the handle, and then remove it to allow the installation of external parts.

Diese Schritte so lange wiederholen, bis dass man eine korrekte Fluchtung des Griffs erreicht und diesen anschließend entfernen, um dann die Installation der externen Bestandteile zu ermöglichen.

Repitan estas operaciones hasta obtener la correcta alineación de la maneta, finalmente remuévanla para permitir la instalación de las partes externas.

Повторите эти операции вплоть до правильного выравнивания ручки, наконец, снимите ее, чтобы обеспечить установку наружных частей.

Επαναλάβετε αυτά τα βήματα μέχρι να πετύχετε τη σωστή ευθυγράμμιση της λαβής, τέλος βγάλτε την για να είναι δυνατή η τοποθέτηση των εξωτερικών μερών.

重复以上操作，直至实现手柄的正确对位，最后从支座上取下手柄，以便能进行内部部件的安装。



SOSTITUZIONE DELLA CARTUCCIA - CARTRIDGE REPLACEMENT - SUBSTITUTION DE LA CARTOUCHE - AUSTAUSCHEN DER  
 KARTUSCHE - SUSTITUCIÓN DEL CARTUCHO - ЗАМЕНА КАРТРИДЖА - ΑΝΤΙΚΑΤΑΣΤΑΣΗ ΤΟΥ ΦΥΣΙΓΓΙΟΥ - 网芯替换

Fig. 1

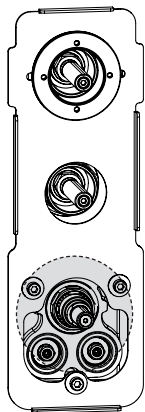

Fig. 2

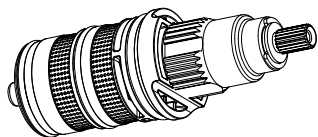
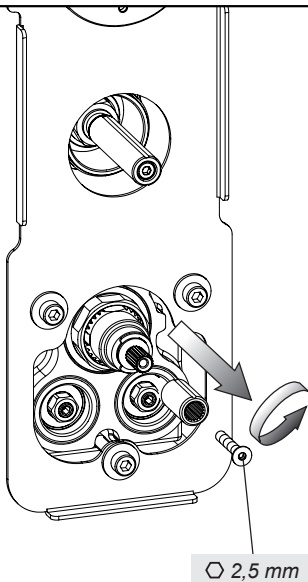
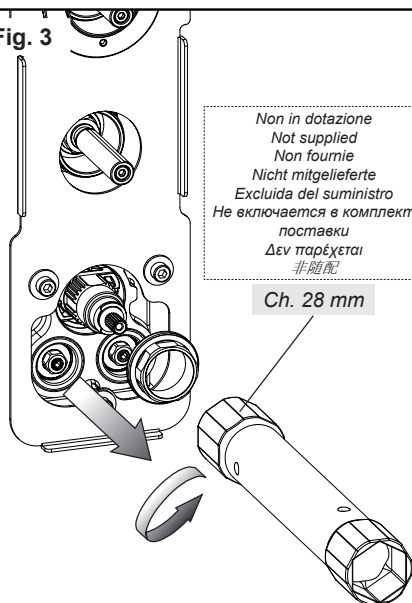
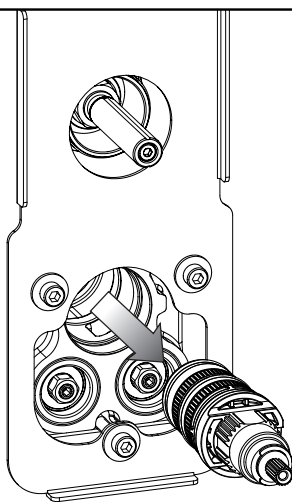

Fig. 3



Non in dotazione  
 Not supplied  
 Non fournie  
 Nicht mitgelieferte  
 Excluida del suministro  
 Не включается в комплект поставки  
 Δεν παρέχεται  
 非随配

Fig. 4





PULIZIA DEI FILTRI IN ENTRATA - INLET FILTERS CLEANING - NETTOYAGE DES FILTRES EN ENTRÉE - REINIGEN DER  
EINGANGSFILTER - LIMPIEZA DE LOS FILTROS DE ENTRADA - ЧИСТКА ВХОДНЫХ ФИЛЬТРОВ - ΚΑΘΑΡΙΣΜΟΣ ΤΩΝ ΦΙΛΤΡΩΝ  
ΣΤΗΝ ΕΙΣΟΔΟ - 清洗进水口过滤装置

Fig. 1

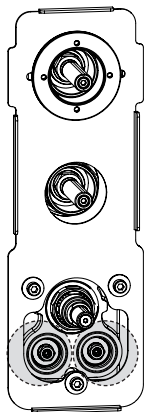

Fig. 2

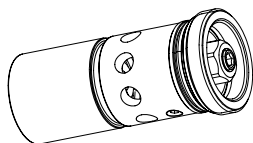
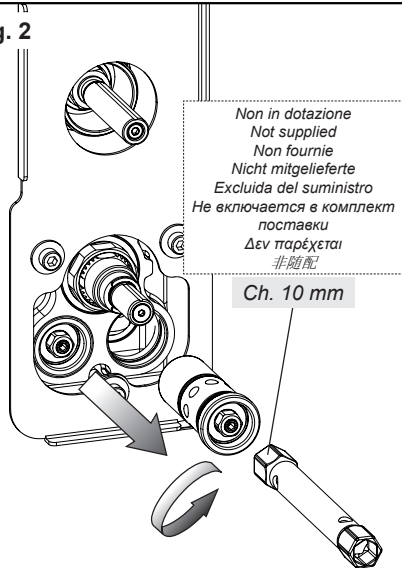

Fig. 3

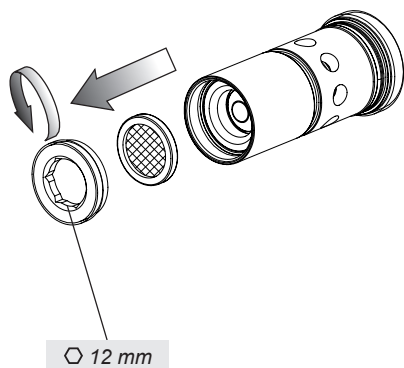

Fig. 4

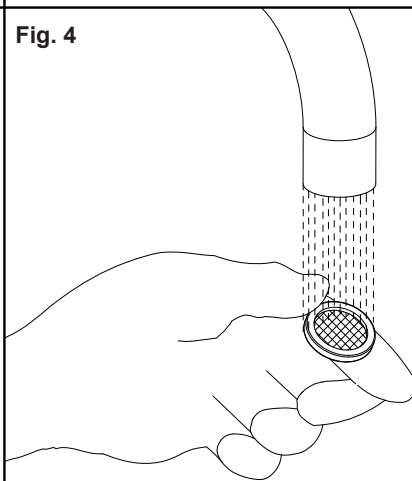



Fig. 1

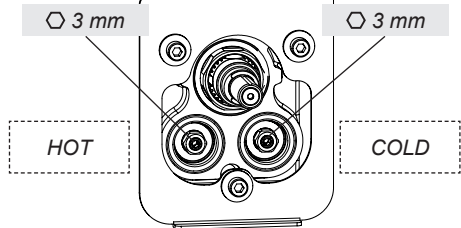

Fig. 2

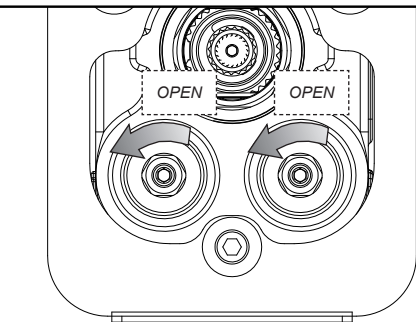
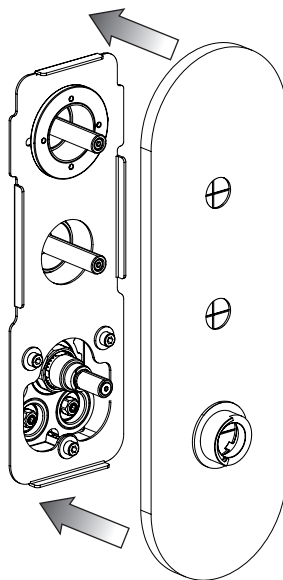

Fig. 3

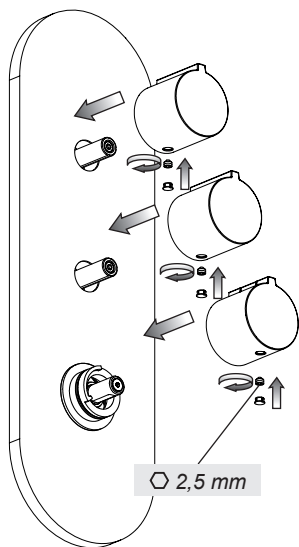

Fig. 4

