

- Ⓓ **Montageanleitung**
- ⒼⒷ **Mounting instructions**
- Ⓕ **Notice de montage**
- ⒶⒻ **Montage-instructie**
- Ⓘ **Istruzioni di montaggio**
- Ⓔ **Instrucciones de montaje**
- ⒴Ⓕ **Instrukcja montażu**

a

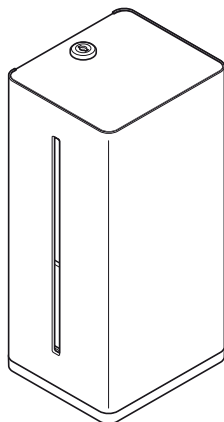

805.06.115
950.06.115

Elektronischer Flüssigseifenspender
Electronic liquid soap dispenser
Distributeur de savon liquide électronique
Elektronische vloeibare-zeep-dispenser
Electronica distributore di sapone liquido
Dispensador electrónico de jabón líquido
Elektroniczny dozownik mydła w płynie

b

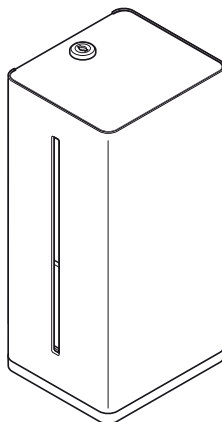

805.06.155
950.06.155

Elektronischer Schaumseifenspender
Electronic foam soap dispenser
Distributeur de savon-mousse électronique
Elektronische schuimzeep-dispenser
Electronica distributore di sapone schiuma
Dispensador electrónico de jabón espuma
Elektroniczny dozownik mydła w pianie

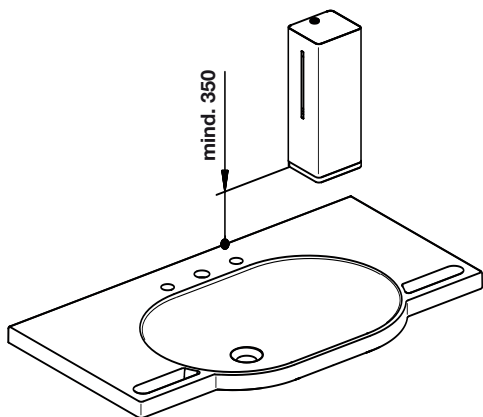

mind. 350

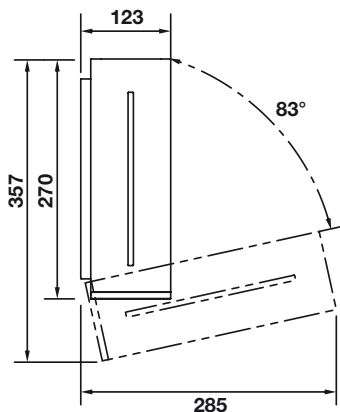

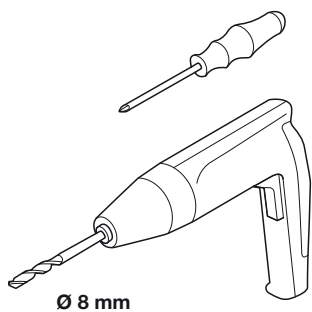

Benötigte Werkzeuge
Tools required
Outillage requis
Benodigd gereedschap
Attrezzi richiesti
Herramientas requeridas
Narzędzi koniecznych

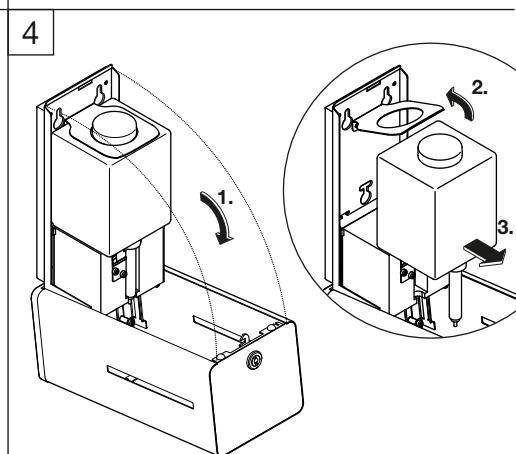
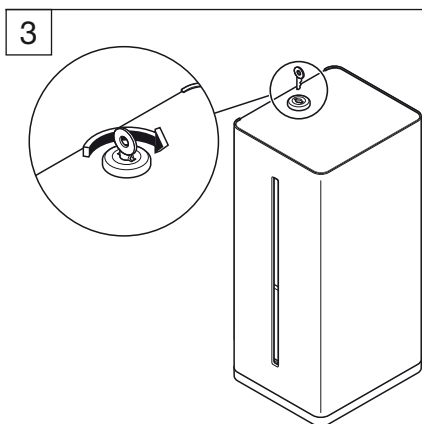
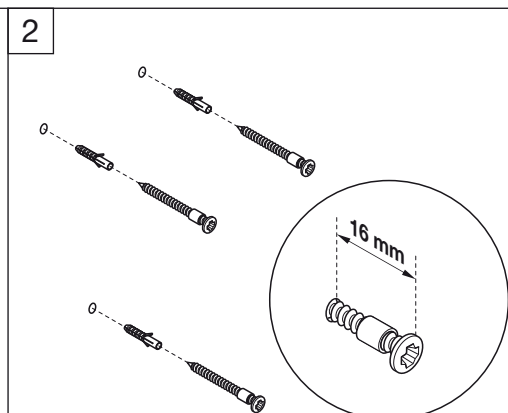
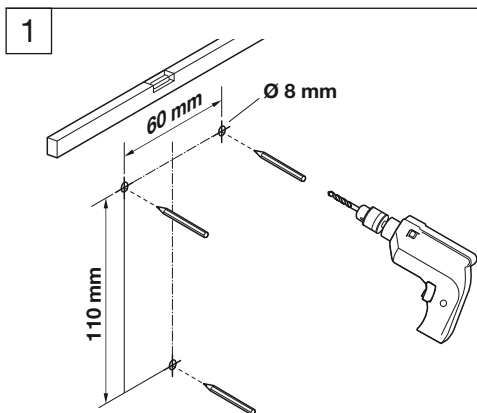

5

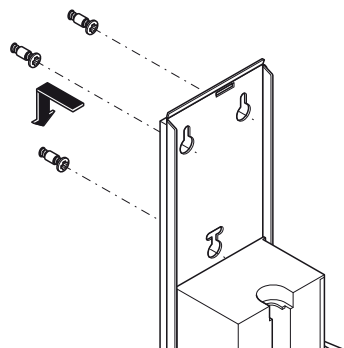

6

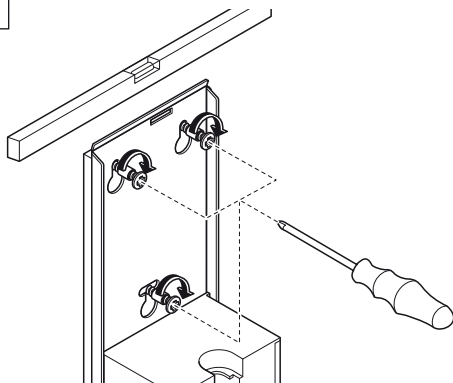

7

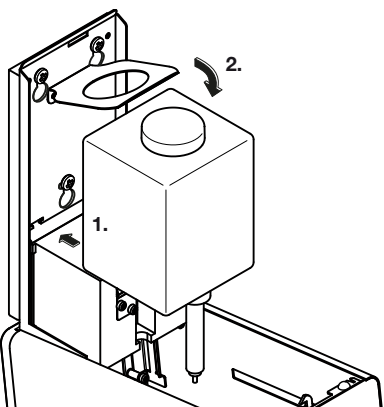

8

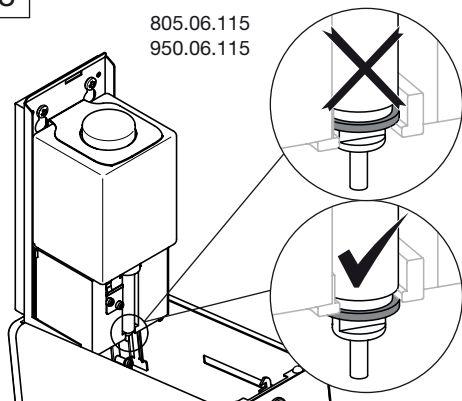

9

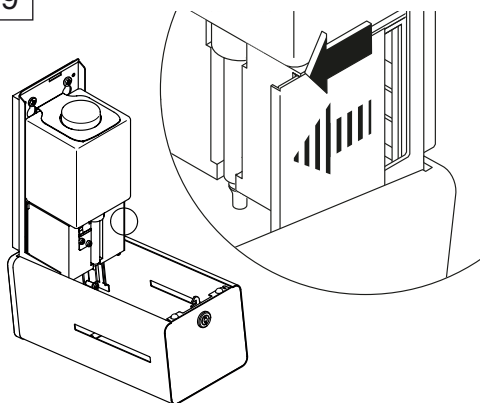

10

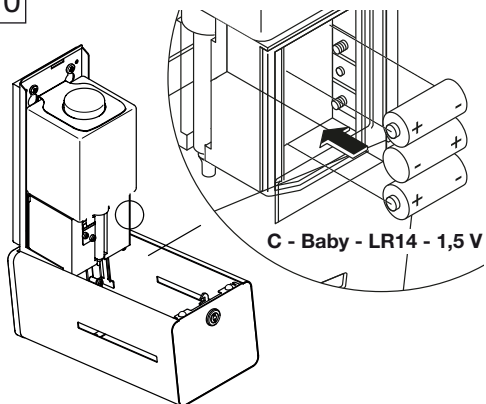

11

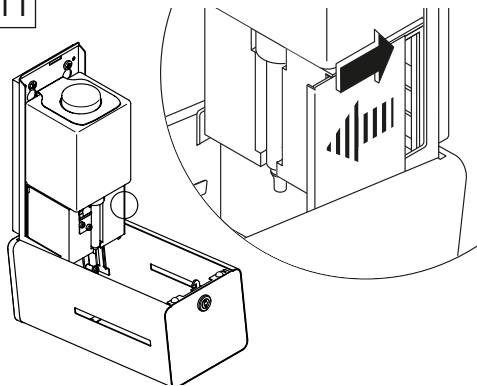

12

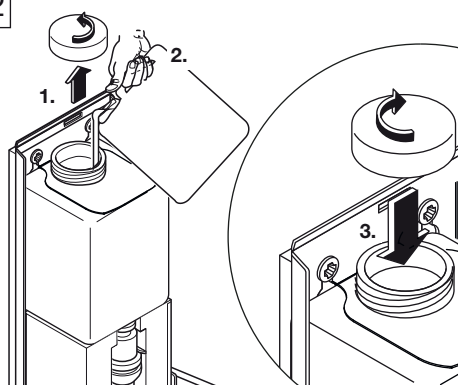

13

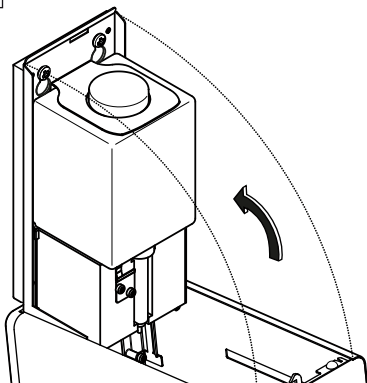

14

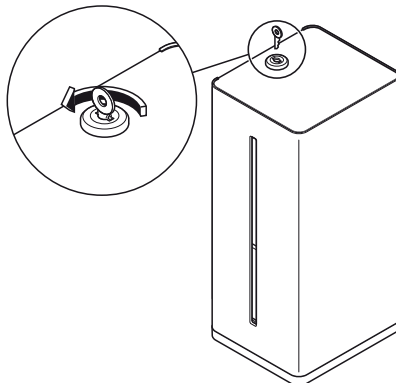

15

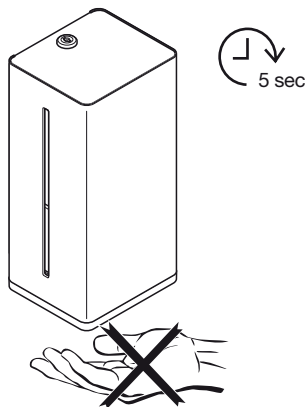

16

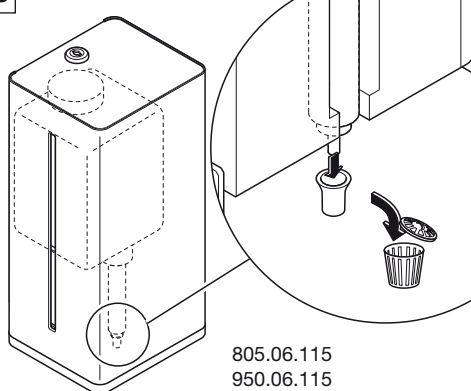

805.06.115
950.06.115

1

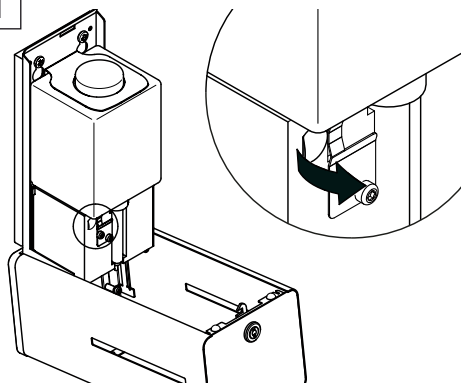

2a

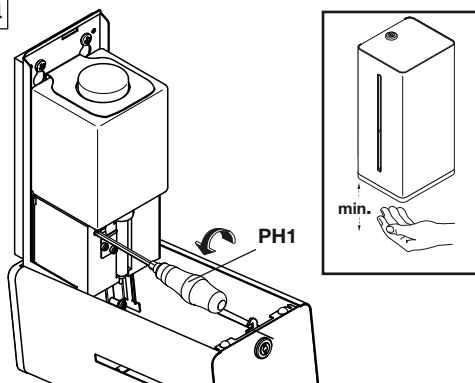

2b

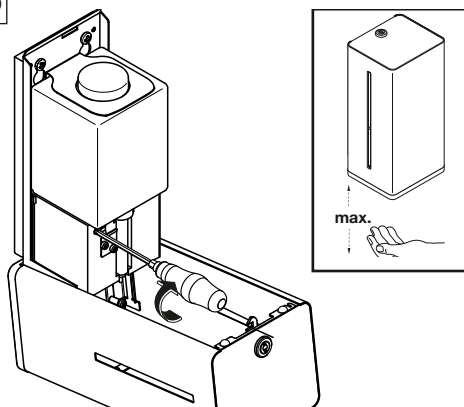

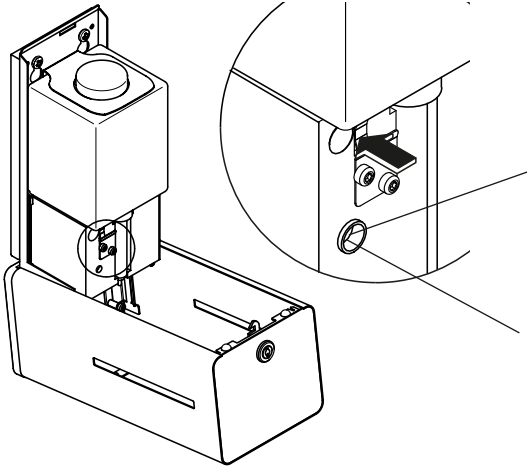

blinkt „rot“
flashes „red“
clignote „rouge“
knippert „rood“
lampeggia „rosso“
destellos „rojo“
miga „czerwony“



leuchtet „rot“
shines „red“
lumières „rouge“
lichten „rood“
semaforo „rosso“
lucos „rojo“
światła „czerwony“



HEWI

www.hewi.com

Deutschland

HEWI Heinrich Wilke GmbH

Postfach 1260

D-34442 Bad Arolsen

Telefon: +49 5691 82-0

Telefax: +49 5691 82-319

info@hewi.de

www.hewi.de